



CANCAN®

• SINCE 1958 •

www.cancan.com.tr

67 Years of Experience

A Brand Producing for the World Since 1958

"It all started in a workshop producing fruit presses."

Since the very first day we were founded, we have grown with our family values and continued to produce with unwavering dedication to our work. Today, in our 6,500 m² production facility, we create industrial kitchen solutions for professionals around the world.

Thanks to our advanced production infrastructure, strong R&D, and commitment to quality, we have become a trusted brand in the industry, exporting to more than 60 countries today.

Every day, we continue working to produce better, reach more regions, and become the most reliable partner for professionals in the kitchen.



60+ COUNTRIES

We directly export 50% of our production to five continents. With our global distributor network and deep understanding of local markets, we offer solutions tailored to each country.



QUALITY

All our production processes are managed in accordance with ISO standards. The use of recyclable materials, long-lasting product design and low energy consumption are among our core principles.



R&D AND INNOVATION

With our engineering infrastructure and the feedback we receive from users, we develop next-generation products every year.



Cancan Quality

The Same Quality in Every Product

"Since 1958, with three generations of production experience, quality is not a goal for us; it is a responsibility."

At Cancan®, we carry out every stage of production entirely in-house, under 100% control. From design to assembly, from welding processes to quality control tests, all steps are executed by our expert teams. Every product is manufactured in-house through advanced production processes, in line with international quality standards.

In our production approach, we think not only about today but also about the future. That's why we prioritize R&D, analyzing customer needs and industry trends to develop innovative solutions. Every one of our products reaches the end user precisely tested and fully compliant with international quality standards.

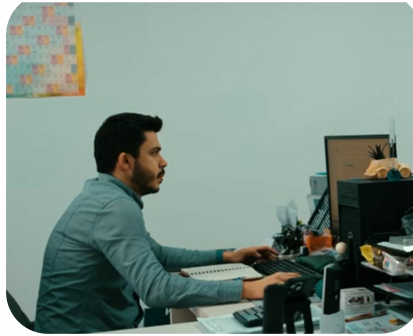



cancanmeyvepresleri



Cancan Meyve Presleri



@CancanTurkey



cancanmakine



www.cancan.com.tr

Index

JUICING EQUIPMENT



Manual Fruit Juicers

- 11 0102 Professional Type Manual Fruit Juicer
- 12 0103 Pomegranate Type Manual Fruit Juicer

Automatic Orange Juicers

- 14 Automatic Orange Juicers Technical Comparison Chart
- 16 Automatic Orange Juicers Comparison Chart
- 18 0206 28 Cafe Type Automatic Orange Juicer
- 20 0203 38 with Glass Automatic Orange Juicer
- 22 0204-1101 38 with Tank and Stand Automatic Orange Juicer
- 24 0205-1101 38 Fresh with Stand Automatic Orange Juicer
- 28 0205-1107 38 Fresh & Stand with Double Trash Can Automatic Orange Juicer
- 30 0208 38 Cooler Model Automatic Orange Juicer

Automatic Pomegranate Juicer

- 33 0603 Automatic Pomegranate Press

- 73 1708 Tamper
- 74 1337 Block Cheese Slicer XL

Fruit and Vegetable Processing Equipments (Industrial Type)

- 76 1305 Pneumatic Potato Cutter
- 77 1342 Electrical Potato Cutter
- 78 1309 Pneumatic Melon Cutter
- 79 1310 Pneumatic Watermelon Cutter
- 80 0809 Pneumatic Pineapple Peeler with Stand

Electrical & Manual Can Openers

- 82 0302 Professional Type Manual Can Opener
- 83 0303 Stainless Manual Can Opener
- 84 0702 Professional Type Electrical Can Opener (Circle Cut)
- 85 0703 Professional Type Electrical Can Opener (Circle-Square Cut)

PREPARATION EQUIPMENT



Preparation Equipments

- 36 1301 Vegetable-Fruit Cutter
- 37 1302 Tomato Slicer
- 38 1308 Small Size Tomato Slicer
- 39 1306 Practical Coring Spoon
- 40 1307 Practical Walnut Opener
- 41 1313 Cheese Slicer
- 42 1319 Onion Flowering Cutter
- 43 1320 Mandoline Slicer
- 44 1321 Manual Potato Cutter
- 45 1323 Vegetable & Fruit Peeler
- 46 1324 Manual Melon Cutting Tool
- 47 1332 Manual Watermelon Cutting Tool
- 48 1327 Manual Watermelon Slicer
- 49 1325 Leaf Cutting
- 50 0810 Pineapple Guillotine Cutter
- 51 0801 Pineapple Peeler
- 52 1326 Manual Pineapple Slicer
- 53 1423 Pineapple Trio
- 54 1315 Fruit Cutter
- 56 1316 Lemon Cutter
- 58 1317 Combined Slicer
- 60 1318 Vertical Tomato Slicer
- 61 1330 Pizza Slicer

New Products

- 62 1333 Sausage Slicer
- 63 1338 Sausage Slicer (Julienne Cut)
- 64 1335 Block Cheese Slicer
- 65 1336 Rail Cheese Slicer
- 66 1334 Spiral Twister Potato Cutter
- 67 1340 Spiral Curly Fry Cutter
- 68 1701 Butter Roller
- 69 1705 Butter Roller XL
- 70 1706 Smash Burger Press (Circular)
- 71 1707 Smash Burger Press (Square)
- 72 1709 Iron Steak Weight

WASHING EQUIPMENT



Washing Equipments

- 88 Washing Equipments Comparison Chart
- 90 0501 MT01 Sink Mounted Pre-Rinse Faucet
- 91 0502 MT02 Sink Mounted Pre-Rinse Faucet with Intermediate Tap
- 92 0503 MT03 Wall Mounted Pre-Rinse Faucet
- 93 0504 MT04 Wall Mounted Pre-Rinse Faucet with Intermediate Tap
- 94 0505 MT05 Mini Size Sink Mounted Pre-Rinse Faucet
- 95 0506 MT06 Mini Size Sink Mounted Pre-Rinse Faucet with Intermediate Tap

Deluxe Series

- 97 0507 MT01 Deluxe Sink Mounted Pre-Rinse Faucet
- 98 0508 MT02 Deluxe Sink Mounted Pre-Rinse Faucet with Intermediate Tap
- 99 0512 MT03 Deluxe Wall Mounted Pre-Rinse Faucet
- 100 0513 MT04 Deluxe Wall Mounted Pre-Rinse Faucet with Intermediate Tap
- 101 0509 MT05 Deluxe Mini Size Sink Mounted Pre-Rinse Faucet
- 102 0510 MT06 Deluxe Mini Size Sink Mounted Pre-Rinse Faucet with Intermediate Tap

Sink Mount Pot Filler

- 104 0511 Sink Mount Pot Filler

Retractable Models

- 106 0905 Retractable Pre-Rinse Faucet with Reel Hose (2mt)
- 107 0901 Retractable Pre-Rinse Faucet with Reel Hose (6mt)
- 108 0902 Retractable Pre-Rinse Faucet with Reel Hose (10mt)
- 109 0903 Retractable Pre-Rinse Faucet with Reel Hose (12mt)
- 110 0904 Retractable Pre-Rinse Faucet with Reel Hose (15mt)

Industrial Type Pot Washing Machine

- 112 1001 Industrial Type Pot Washing Machine

NEW PRODUCTS



1333

Sausage
Slicer

01

You can find the product
details on page **62**



1338

Sausage
Slicer
(Julienne Cut)

02

You can find the product
details on page **63**



1335

Block
Cheese
Slicer

03

You can find the product
details on page **64**



1336

Rail
Cheese
Slicer

04

You can find the product
details on page **65**

NEW PRODUCTS

05

1337

Block
Cheese
Slicer XL

You can find the product
details on page **74**



06

1334

Spiral
Twister
Potato Cutter

You can find the product
details on page **66**



07

1340

Spiral
Curly
Fry Cutter

You can find the product
details on page **67**



08

1342

Electrical
Potato
Cutter

You can find the product
details on page **77**



NEW PRODUCTS



1705

Butter
Roller XL

09

You can find the product
details on page **69**



1706

Smash
Burger Press
(Circle)

10

You can find the product
details on page **70**



1707

Smash
Burger Press
(Square)

11

You can find the product
details on page **71**



1709

Iron
Steak
Weight

12

You can find the product
details on page **72**



1708

Tamper

13

You can find the product
details on page **73**

JUICING EQUIPMENT





Juicing Equipment

Manuel Fruit Juicers

Manual Fruit Presses are designed for cafés, buffets, restaurants, and businesses looking to add fresh juice to their menus by efficiently squeezing citrus fruits such as oranges, pomegranates, lemons and grapefruits. With an ergonomic structure and NSF-certified food safety compliance, they fully meet hygiene and health standards. These manual presses deliver high performance with a two-stage squeezing system and feature stainless steel strainers that are removable and dishwasher-safe, ensuring low pulp output and a clean, efficient pressing process. A non-slip plastic base provides safe operation. This design is compatible with all types of citrus fruits, offering businesses both maximum efficiency and convenience.



0102

**Professional Type
Manual Fruit Juicer**



0103











**Pomegranate Type
Manual Fruit Juicer**



0102

Professional Type Manual Fruit Juicer

Equipped with a locking strainer and bowl, the Professional Type Manual Fruit Juicer has a squeezing force of 90 kg and is designed for use in cafes, buffets, and restaurants. The drip feature prevents fruit juice from leaking out between squeezes.

-  NSF Certified
-  Two-Step Squeezing
-  Locking Stainless Steel Strainer
-  High Performance
-  Easy Cleaning
-  Non-Slip Base
-  Drip Cup
-  Adjustable Height
-  Ergonomic Upperpress
-  Exclusive Cancan® Design

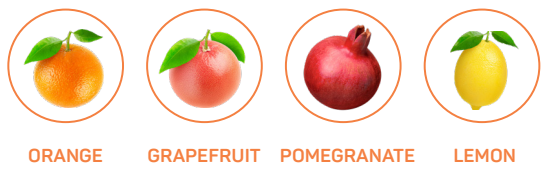

Technical Specifications

PRODUCT NAME	PRODUCT CODE	DIMENSIONS	WEIGHT
PROFESSIONAL TYPE MANUAL FRUIT JUICER	0102	18x30x65 cm	4,5 kg



0103

Pomegranate Type Manual Fruit Juicer

Equipped with a locking strainer and bowl, the Pomegranate Type Manual Fruit Juicer is designed with a larger top press diameter (11.5 cm) to make squeezing large pomegranates easier. It offers high efficiency with a squeezing force of 90 kg. Its drip cup prevents juice from leaking during squeezing. The support handle is designed for ease of use when pressing. It is developed for use in places such as cafes, buffets, and restaurants.



NSF Certified



Two-Step Squeezing



Locking Stainless Steel Strainer



High Performance



Easy Cleaning



Non-Slip Base



Drip Cup



Adjustable Height



Ergonomic Upperpress



Exclusive Cancan® Design



ORANGE



GRAPEFRUIT



POMEGRANATE



LEMON

Technical Specifications

PRODUCT NAME	PRODUCT CODE	DIMENSIONS	WEIGHT
POMEGRANATE TYPE MANUAL FRUIT JUICER	0103	20x30x65 cm	4,75 kg



Juicing Equipment

Automatic Orange Juicers

Automatic Orange Juicers are ideal for quickly and efficiently squeezing citrus fruits such as oranges and lemons in hotels, restaurants, hospitals, commercial centers, shopping malls, dormitories, universities, and juice bars. With a single button, they automatically perform the feeding, cutting, and squeezing processes. Cancan® Juicers can squeeze 28 or 38 oranges per minute. With glass serving, self-service, storage tank, and refrigerated models, they meet various needs and offer flexibility with stand and bottle holder accessories. The squeezing process occurs hands-free, ensuring guaranteed hygiene. The Automatic Orange Juicer system prevents contact between the juice and the peel, stopping the acid from the orange peel from mixing into the juice. This results in high-quality, flavorful juice.



Automatic Orange Juicers

TECHNICAL COMPARISON CHART

The CANCAN® Automatic orange juicers are designed to extract citrus fruits such as oranges, mandarins and lemons in public places such as hotels, restaurants, commercial centers, entertainment and shopping centers, dormitories, universities, snack bars, etc.

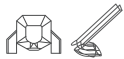
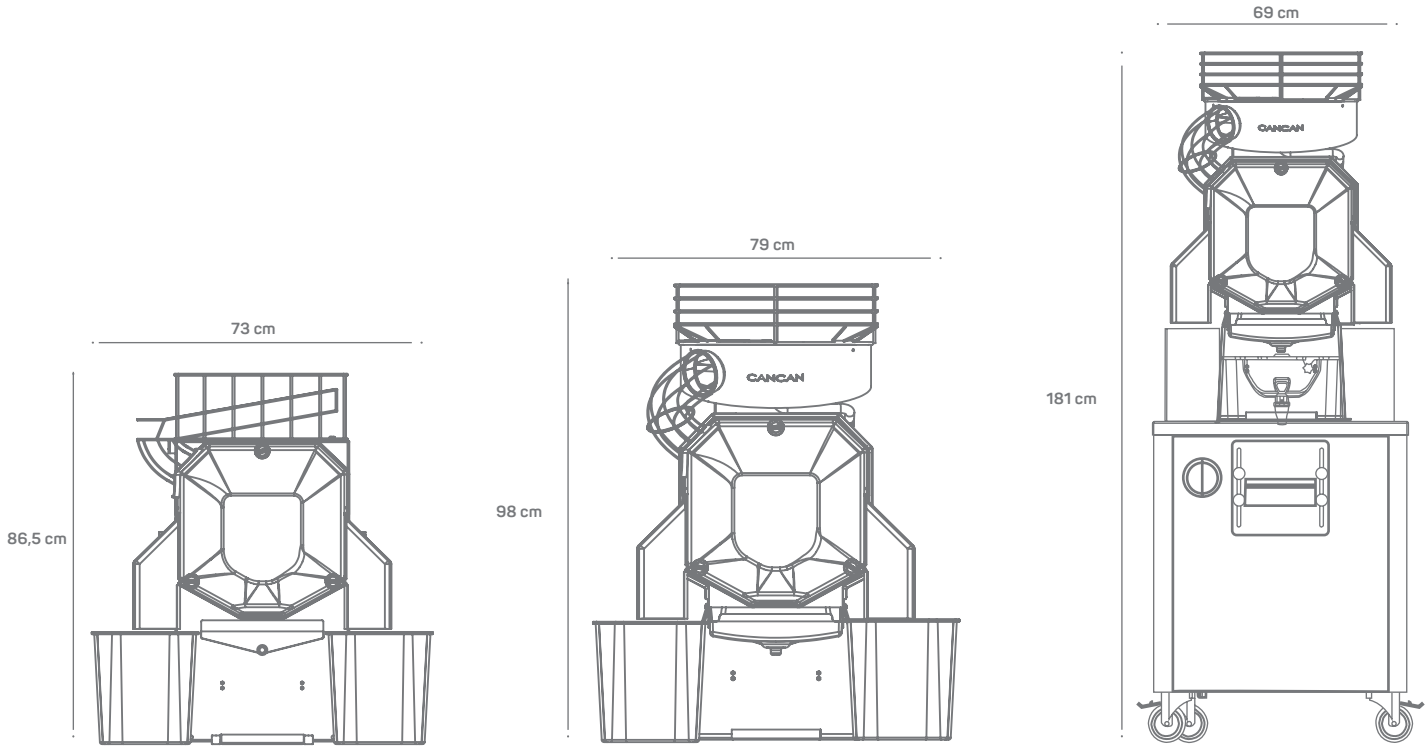

Product Code: 0206
Product Name: Cafe Type



Product Code: 0203
Product Name: With Glass

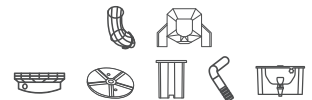

Product Code: 0204 - 1101
Product Name: With Tank & Stand

Orange Squeezing:	28 units/min.	38 units/min.	38 units/min.
Orange Diameter:	Ø 6-8 cm	Ø 6 - 8 cm	Ø 6 - 8 cm
Orange Basket:	7 kg	15 kg	15 kg
Power:	0,25 kw	0,37 kw	0,37 kw
Current:	2,1 A	2,5 A	2,5 A
Voltage:	220 - 240 V	220 - 240 V	220 - 240 V
Frequency:	50 - 60 Hz	50 - 60 Hz	50 - 60 Hz
Weight:	45 kg	76 kg	117 kg
Width:	72 cm	75 cm	69 cm
Depth:	41.5 cm	58 cm	70 cm
Height:	86.5 cm	98 cm	181 cm

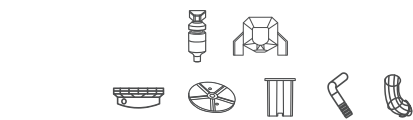
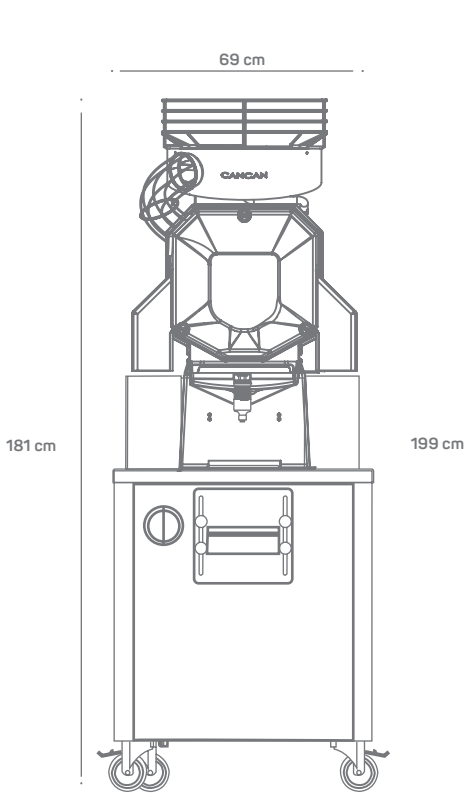

Product Code: 0205 - 1101
Product Name: Fresh With Stand

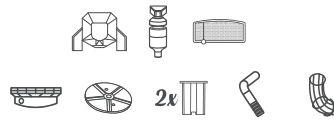
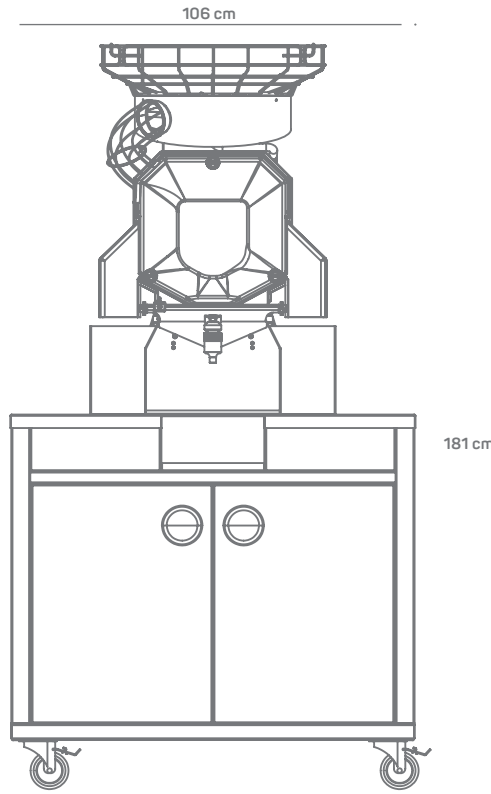

Product Code: 0205 - 1107
Product Name: Double Trash Can

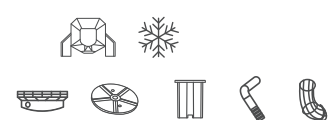
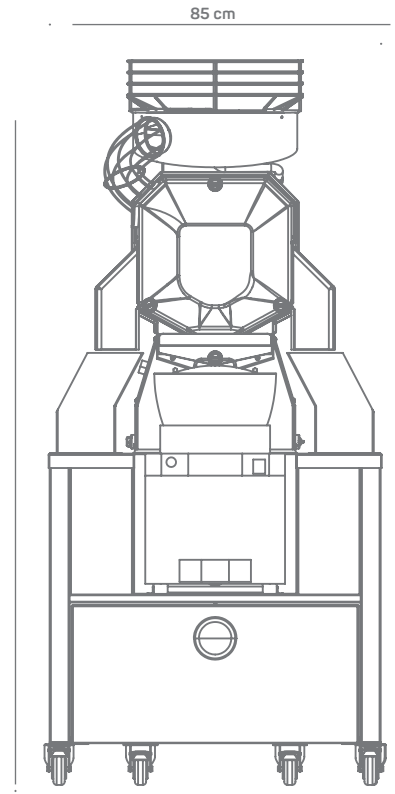

Product Code: 0208
Product Name: Cooler Model

38 units/min.	38 units/min.	38 units/min.
Ø 6 - 8 cm	Ø 6 - 8 cm	Ø 6 - 8 cm
15 kg	28 kg	15 kg
0,37 kw	0,37 kw	0,37 kw
2,5 A	2,5 A	2,5 A
220 - 240 V	220 - 240 V	220 - 240 V
50 - 60 Hz	50 - 60 Hz	50 - 60 Hz
117 kg	137 kg	149 kg
69 cm	106 cm	85 cm
70 cm	94 cm	82 cm
181 cm	199 cm	181 cm

Automatic Orange Juicers

COMPARISON CHART

Which Automatic Orange Juicer is Right for You?



0206
28 CAFE TYPE



0203
38 WITH GLASS



0204-1101
38 WITH TANK AND STAND



0205-1101
38 FRESH WITH STAND



0205 - 1107
38 FRESH & STAND WITH DOUBLE TRASH CAN



0208
COOLER MODEL

	0206 28 CAFE TYPE	0203 38 WITH GLASS	0204-1101 38 WITH TANK AND STAND	0205-1101 38 FRESH WITH STAND	0205 - 1107 38 FRESH & STAND WITH DOUBLE TRASH CAN	0208 COOLER MODEL
Large Feeding Wire		✓	✓	✓	✓	✓
Fruit Feeding Wire	✓					
Fruit Storage Basket	✓	✓	✓	✓	✓	✓
Front Cover with a Safety Switch	✓	✓	✓	✓	✓	✓
Juice Tank			✓			
Self Service System				✓	✓	
Rotating Disk		✓	✓	✓	✓	✓
Cooler System						✓
Cleaning Pipe		✓	✓	✓	✓	✓
Large Volume Trash Can			✓	✓		
Double Trash Can					✓	
Easily Cleanable Stainless Strainer				✓	✓	✓

The Most Suitable Model for the Your Business

Cafe	Restaurant	Catering	Market	Production Facility	Hotel
<p>This automatic fruit press is primarily an ideal solution for cafés, while also offering practical and efficient use in restaurants, bars, and similar establishments.</p> <p>0206 28 CAFE TYPE</p>	<p>Primarily designed for cafés, this automatic fruit press also ensures practical and efficient performance in restaurants, bars, and catering services.</p> <p>0203 38 WITH GLASS</p>	<p>Primarily designed for catering operations, this machine is equally effective in greengroceries, supermarkets, and facilities producing fruit juice in bulk.</p> <p>0204-1101 38 WITH TANK AND STAND</p>	<p>This model is primarily recommended for supermarkets, but it is also suitable for use in hotels, cafés, restaurants, and buffets.</p> <p>0205-1101 38 FRESH WITH STAND</p>	<p>Primarily designed for environments with high-volume juice extraction, this model is also well-suited for supermarkets and hotels.</p> <p>0205 - 1107 38 FRESH & STAND WITH DOUBLE TRASH CAN</p>	<p>Designed mainly for hotel buffet setups, this model also provides effective use in restaurants and various event spaces.</p> <p>0208 38 COOLER MODEL</p>

Can you not make a decision?

Get in touch with us.

Let's choose the most suitable model together!









www.cancan.com.tr

0206

28 Cafe Type Automatic Orange Juicer

The Cafe-type Automatic Orange Juicer is ideal for a wide range of establishments, including hotels, restaurants, markets, shopping malls, hospitals, student dormitories, cafes, and universities. It is designed for juicing citrus fruits such as oranges and lemons in public settings. The machine features a manually fed hopper that can hold up to 7 kg of fruit. It squeezes approximately 28 oranges per minute and, depending on the feeding speed, can produce up to 100 glasses per day. This makes it especially suitable for cafeterias.

-  7 kg Fruit Storage Basket
-  28 Glass Per Minute Orange Squeezing Capacity
-  9-Orange Capacity Manual Feed Wire
-  Front Cover with a Safety Switch
-  Dishwasher-Safe Removable Components
-  Optional Lemon Kit

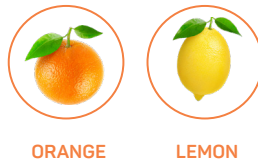

Technical Specifications







28 CAFE TYPE AUTOMATIC ORANGE JUICER				
PRODUCT NAME	28 CAFE TYPE AUTOMATIC ORANGE JUICER			
PRODUCT CODE	DIMENSIONS	WEIGHT	ORANGE SQUEEZING	ORANGE DIAMETER
0206	72x41,5x86,5 cm	45.2 kg	28 units/min.	6-8 cm
ORANGE BASKET	POWER	CURRENT	VOLTAGE	FREQUENCY
7 KG	0,25 kW	2.1 A	220 - 240 V	50 - 60 Hz

0206

Product Applications

Recommended for Cafés



- 
Cafe
- 
Restaurant
- 
Catering
- 
Market
- 
Hotel
- 
Production Facility

SPARE PARTS



Squeezing Balls



Trash Cans



Start & Stop Buton



Upper Basket



Fruit Feeding Wire



Strainer & Strainer Tray



Stainless Steel Dropper



Peelers

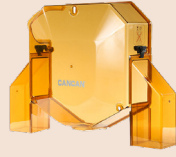

Front Cover











Blade

0203

38 with Glass Automatic Orange Juicer

The 38 With Glass Automatic Orange Juicer is designed for businesses to efficiently squeeze citrus fruits such as oranges and lemons. With just one button, it automatically performs the feeding, cutting, and squeezing processes. Cancan's technology ensures that the juice and the peel do not come into contact, preventing peel acids from entering the juice and preserving its flavor. The machine features a stainless steel body, a rotating disc, and a self-cleaning system. Its hygienic juice extraction system offers guaranteed hygiene by operating hands-free. It also includes a 15 kg fruit storage chamber and provides a practical, user-friendly design for businesses.

-  Fruit Storage Basket: 15 kg or 28 kg (Optional)
-  38 Glass Per Minute Orange Squeezing Capacity
-  Rotating Disc
-  Large Feeding Wire
-  Dishwasher-Safe Removable Components
-  Front Cover with a Safety Switch
-  Cleaning Pipe
-  Optional Lemon Kit

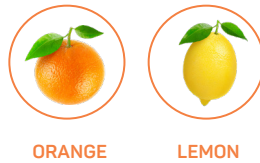

Technical Specifications







PRODUCT NAME	38 WITH GLASS AUTOMATIC ORANGE JUICER			
PRODUCT CODE	DIMENSIONS	WEIGHT	ORANGE SQUEEZING	ORANGE DIAMETER
0203	75x58x98 cm	76 kg	38 units/min.	6-8 cm
ORANGE BASKET	POWER	CURRENT	VOLTAGE	FREQUENCY
15 KG	0,37 kW	2,5 A	220 - 240 V	50 - 60 Hz

0203











Product Applications

Recommended for Restaurants

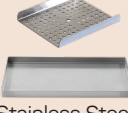

- 
Cafe
- 
Restaurant
- 
Catering
- 
Market
- 
Hotel
- 
Production Facility

SPARE PARTS

 Squeezing Balls	 Trash Cans	 Start & Stop Button	 Large Feeding Wire	 Upper Basket
 Strainer & Strainer Tray	 Stainless Steel Dropper	 Peelers & Blade	 Front Cover	 Rotating Disc

ACCESSORIES



Loading Bunker
0402



Bottle Stand
1117



Mobile Stand
1101













Mobile Stand with Double
Trash Can
1107

0204 - 1101

38 with Tank And Stand Automatic Orange Juicer

The 38 Automatic Orange Juicer With Tank, with its large storage capacity, offers practical service convenience in high-capacity environments. It is designed for businesses to efficiently squeeze citrus fruits and serve fresh juice. With just one button, it automatically performs the feeding, cutting, and squeezing processes. The peel waste is collected in the large trash can. The juicer has a fully stainless steel body, a mobile stand with wheels, a strengthened frame, and a bottle holder, offering both hygiene and safe use. It also includes a 15 kg fruit storage basket and provides maximum efficiency in busy environments.

-  Fruit Storage Basket: 15 kg or 28 kg (Optional)
-  38 Glass Per Minute Orange Squeezing Capacity
-  Optional Mobile Stand
-  Rotating Disc
-  70 kg Large Volume Trash Can
-  Large Feeding Wire
-  Dishwasher-Safe Removable Components
-  Juice Tank
-  Front Cover with a Safety Switch
-  Cleaning Pipe
-  Optional Lemon Kit



Juice Tank



ORANGE



LEMON

Technical Specifications

PRODUCT NAME	38 WITH TANK AND STAND AUTOMATIC ORANGE JUICER			
PRODUCT CODE	DIMENSIONS	WEIGHT	ORANGE SQUEEZING	ORANGE DIAMETER
0204-1101	69x70x181 cm	117 kg	38 units/min.	6-8 cm
ORANGE BASKET	POWER	CURRENT	VOLTAGE	FREQUENCY
15 KG	0,37 kW	2,5 A	220 - 240 V	50 - 60 Hz

0204 - 1101

Product Applications

Recommended for Caterings



Cafe



Restaurant



Catering



Market



Hotel



Production Facility

SPARE PARTS



Squeezing Balls



Trash Cans



Start & Stop Button



Large Feeding Wire



Upper Basket



Strainer & Strainer Tray

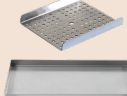

Stainless Steel Dropper



Peelers & Blade



Front Cover



Rotating Disc

ACCESSORIES



Loading Bunker
0402



Bottle Stand
1117



Mobile Stand
1101

0205-1101

38 Fresh with Stand Automatic Orange Juicer

The 38 Fresh Automatic Orange Juicer with a self-service tap is an ideal solution for restaurants, markets, cafes, universities, and similar establishments to serve fresh citrus juice quickly and hygienically. Made from 304 stainless steel, its self-service tap allows easy juice dispensing. With one button, the machine feeds, cuts, and squeezes automatically, while peel waste is collected in a large container. Its stainless steel body, reinforced frame, and mobile stand ensure hygiene, practicality, and safety. It squeezes about 38 oranges per minute and meets demands of over 100 glasses per day.

- Fruit Storage Basket: 15 kg or 28 kg (Optional)
- 38 Glass Per Minute Orange Squeezing Capacity
- Optional Mobile Stand
- Rotating Disc
- 70 kg Large Volume Trash Can
- Large Feeding Wire
- Dishwasher-Safe Removable Components
- Self Service System Tap
- Front Cover with a Safety Switch
- Cleaning Pipe
- Optional Lemon Kit
- Strainer and Storage Compatible with Citrus Fruits



Self Service System Tap

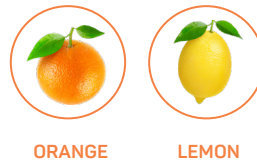

Technical Specifications

PRODUCT NAME	38 FRESH WITH STAND AUTOMATIC ORANGE JUICER			
PRODUCT CODE	DIMENSIONS	WEIGHT	ORANGE SQUEEZING	ORANGE DIAMETER
0205-1101	69x70x181 cm	117 kg	38 units/min.	6-8 cm
ORANGE BASKET	POWER	CURRENT	VOLTAGE	FREQUENCY
15 KG	0,37 kW	2,5 A	220 - 240 V	50 - 60 Hz

0205-1101

Product Applications

Recommended for Markets

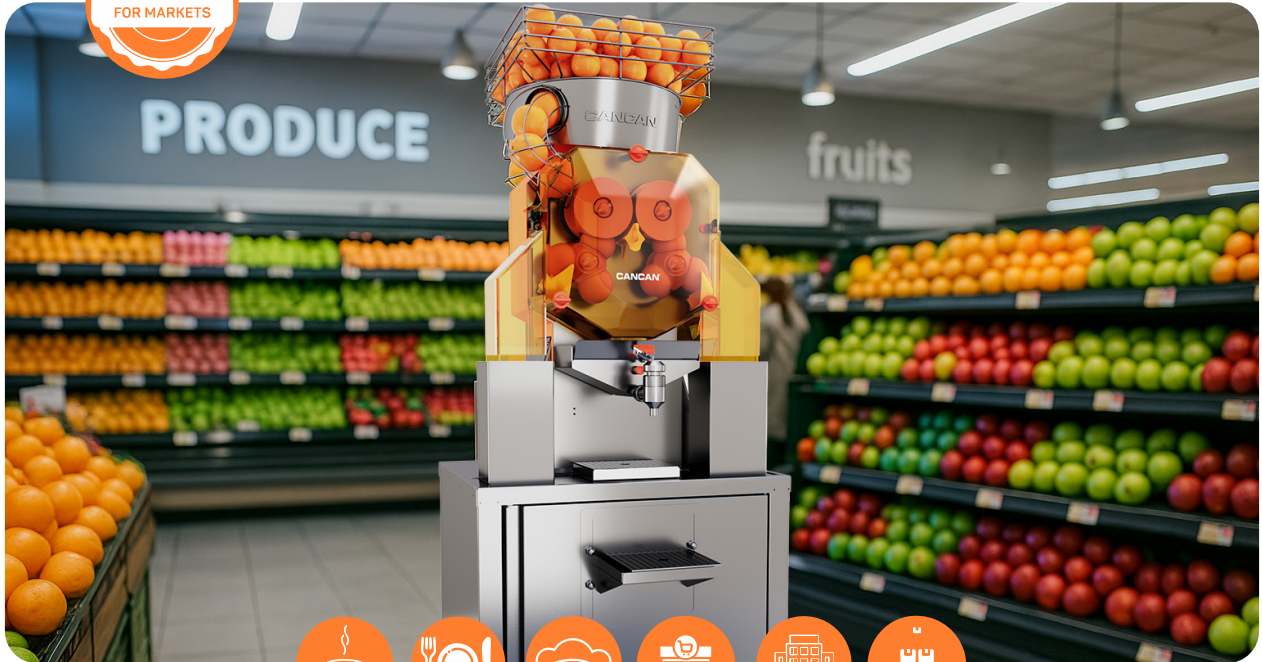

Cafe Restaurant Catering Market Hotel Production Facility

SPARE PARTS

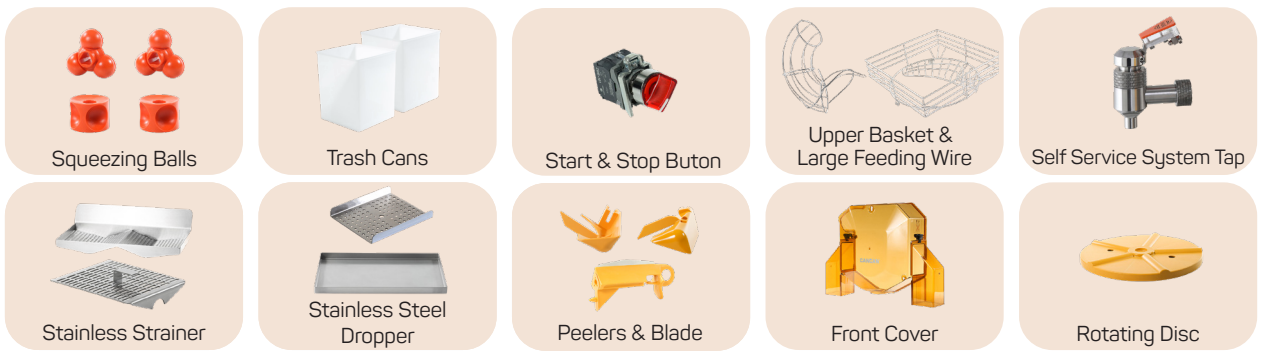

ACCESSORIES



Loading Bunker
0402



Bottle Stand
1117



Mobile Stand
1101



Mobile Stand with Double
Trash Can
1107

0205-1101 Product Details



15 kg Fruit Storage Basket



Large Feeding Wire



Strainer and Storage Compatible with Citrus Fruit



70 kg Large Volume Trash Can



Front Cover with a Safety Switch



Mobile Stand
1101



Bottle Stand
1117



Self Service System Tap
76158



CHOOSE YOUR ACCESSORIES



0205-1107 Product Details



28 kg Fruit Storage Basket



Large Feeding Wire



Strainer and Storage Compatible
with Citrus Fruit

2x



150 kg Large Volume
Trash Can



Front Cover with a
Safety Switch



Loading Bunker
0402



28 kg Fruit Storage Basket
76269













Mobile Car with Double Trash Can
1107

0205-1107

38 Fresh & Stand with Double Trash Can

The 38 Fresh & Stand with Double Trash Can with self-service tap is designed for restaurants, markets, shopping malls, hospitals, dormitories, cafes, and universities to offer fresh citrus juice hygienically and efficiently. Made entirely of 304 stainless steel, the self-service tap allows users to obtain juice easily by pressing the tap. With one button, the machine automatically performs feeding, cutting, and squeezing processes. Peel waste is collected in the double trash can system, increasing capacity and operational efficiency. The strengthened body and mobile stand with wheels ensure practical, hygienic, and safe use.

-  Fruit Storage Basket: 15 kg or 28 kg (Optional)
-  38 Glass Per Minute Orange Squeezing Capacity
-  Optional Mobile Stand
-  Rotating Disc
-  150 kg Double Trash Can
-  Large Feeding Wire
-  Dishwasher-Safe Removable Components
-  Front Cover with a Safety Switch
-  Cleaning Pipe
-  Optional Lemon Kit
-  Strainer and Storage Compatible with Citrus Fruits

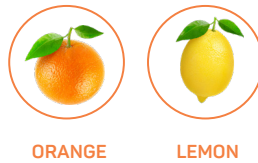

Technical Specifications

PRODUCT NAME	38 FRESH & STAND WITH DOUBLE TRASH CAN			
PRODUCT CODE	DIMENSIONS	WEIGHT	ORANGE SQUEEZING	ORANGE DIAMETER
0205-1107	106x70x199 cm	137 kg	38 units/min.	6-8 cm
ORANGE BASKET	POWER	CURRENT	VOLTAGE	FREQUENCY
28 KG	0,37 kW	2,5 A	220 - 240 V	50 - 60 Hz

0205-1107

Product Applications

Recommended for Production Facility



- Cafe
- Restaurant
- Catering
- Market
- Hotel
- Production Facility

SPARE PARTS

- Squeezing Balls
- Trash Cans
- Start & Stop Buton
- Upper Basket & Large Feeding Wire
- Self Service System Tap
- Stainless Strainer
- Stainless Steel Dropper
- Peelers & Blade
- Front Cover
- Rotating Disc

ACCESSORIES



Loading Bunker
0402



Bottle Stand
1117



Mobile Stand
1101













Mobile Stand with Double
Trash Can
1107

0208

38 Cooler Model Automatic Orange Juicer

The 38 Cooler Model Automatic Orange Juicer, equipped with a bottom cooling system, is designed to quickly squeeze citrus fruits such as oranges and lemons in supermarkets and markets. The 6-minute cooling feature ensures that the juice is kept evenly cool until the last drop, while the stainless steel structure guarantees hygiene by preventing contact between the orange juice and external surfaces. The system collects peel waste directly into the waste can. Its fully stainless steel body, strengthened mobile stand, and lockable wheels provide practical, safe, and flexible use.

-  Fruit Storage Basket: 15 kg or 28 kg (Optional)
-  38 Glass Per Minute Orange Squeezing Capacity
-  Rotating Disc
-  150 kg Large Volume Trash Can
-  Large Feeding Wire
-  Cleaning Pipe
-  Dishwasher-Safe Removable Components
-  Front Cover with a Safety Switch
-  Cooler System
-  Optional Lemon Kit

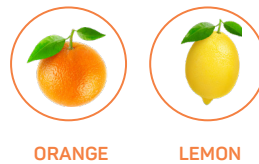

ORANGE

LEMON

Technical Specifications

PRODUCT NAME	38 COOLER MODEL AUTOMATIC ORANGE JUICER			
PRODUCT CODE	DIMENSIONS	WEIGHT	ORANGE SQUEEZING	ORANGE DIAMETER
0208	85x82x181 cm	149 kg	38 units/min.	6-8 cm
ORANGE BASKET	POWER	CURRENT	VOLTAGE	FREQUENCY
15 KG	0,37 kW	2,5 A	220 - 240 V	50 - 60 Hz



0208

Product Applications

Recommended for Hotels



Cafe



Restaurant



Catering



Market



Hotel



Production Facility

SPARE PARTS

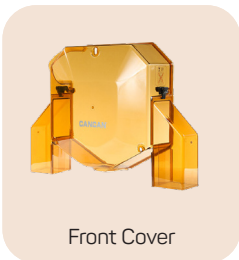
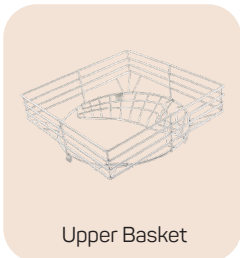
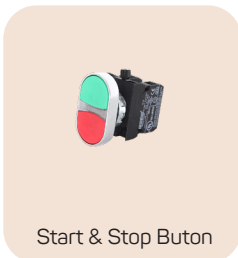



Juicing Equipment

Automatic Pomegranate Juicers

Automatic Pomegranate Press is a professional machine designed to quickly, efficiently, and effortlessly squeeze all types of citrus fruits, especially pomegranates. This model eliminates the difficulties of manually squeezing hard-shelled citrus like pomegranates, providing hygienic and high-efficiency juicing while preserving nutritional value. It is ideal for high-usage businesses such as cafes and restaurants. One of its most important advantages is its ability to squeeze different citrus fruits such as oranges, pomegranates, and lemons simultaneously. Thanks to this feature, it offers great practicality for businesses that want to prepare mixed fruit juices. Additionally, its easy-to-clean design makes it user-friendly.











0603

Automatic Pomegranate Press

The award-winning Automatic Pomegranate Press is designed for use in hotels, restaurants, commercial centers, entertainment venues, shopping malls, student dormitories, universities, and juice buffets. One of its most important advantages is its ability to squeeze a wide variety of fruits with a single machine. Thanks to its hydraulic pressing system, it can easily squeeze pomegranates, oranges, grapefruits and lemons providing hygienic, high-efficiency juicing. The double filtering system ensures that pulp does not mix into the juice. Its compact stainless steel body and easily removable parts make cleaning practical and easy.

-  8-Second Squeezing
-  Mixed Fruit Squeezing
-  Double Filter For Lower Pulp
-  Safety Switch Cover
-  Spare Top Strainer
-  IP Certified Control Button
-  Easy Cleaning



ORANGE POMEGRANATE LEMON GRAPEFRUIT

Technical Specifications

PRODUCT NAME	PRODUCT CODE	DIMENSIONS	SQUEEZING POWER	WEIGHT
AUTOMATIC POMEGRANATE PRESS	0603	31x42x68 cm	1000 KG	50 KG
PRESSING PLATE SIZE	CUP RESERVOIR HEIGHT	FRUIT SQUEEZING	FRUIT DIAMETER	15 KG
13x24 cm	17 cm	6 units/min.	13 cm	7 KG
POWER	CURRENT	VOLTAGE	FREQUENCY	
0,55 KW	4,5 A	220 - 240 V	50 - 60 HZ	

PREPARATION EQUIPMENT





Preparation Equipments **Cutters & Slicers**

CANCAN® Preparation Equipment enables fast, safe, and hygienic operations such as slicing, chopping, peeling, and can opening in professional kitchens. Thanks to their stainless steel bodies, these machines offer long-lasting use and fully meet hygiene standards with their easy-to-clean design. Their ergonomic structures reduce labor effort in the kitchen, while specially designed blades deliver fast, uniform, and aesthetically pleasing cuts. With both manual and pneumatic model options, they adapt to kitchens of various scales, making preparation processes practical, efficient, and effortless.



1301

Vegetable-Fruit Cutter

Designed for industrial kitchens, the Vegetable-Fruit Cutter ensures fast and precise slicing while preserving the freshness of vegetables with its sturdy body and high-quality stainless steel blades. With interchangeable blade systems, it offers three different cutting sizes, allowing quick setup and easy cleaning. Its special handle mechanism enables products to be sliced with minimal force, while the pusher block ensures uniform cuts without crushing the product. The manual locking pin increases safety before use.



Sharp Blades



Manual Locking Pin



Tilted Rubber Feet



Pushing Block



Special Handle Mechanism



LETTUCE



CABBAGE



EGGPLANT



MANGO



COOKED CHICKEN MEAT

Blade Options



1301-1

12,5mmx12,5mm



1301-2

25mmx25mm



1301-3

25mmx50mm

Technical Specifications

PRODUCT NAME	PRODUCT CODE	MAXIMUM LETTUCE DIAMETER	DIMENSIONS	WEIGHT
VEGETABLE-FRUIT CUTTER	1301	17 cm	32x45x74 cm	9,5 kg



1302

Tomato Slicer

The Tomato Slicer, manufactured from stainless steel and reinforced with durable components, is designed for heavy use in industrial kitchens. Thanks to its serrated blades, it effortlessly slices hard and even unripe tomatoes while preserving their freshness and flavor. Its ergonomic handle provides safe and comfortable use, while special vacuumed rubber feet keep the machine stable on the surface. The detachable table stabilizer ensures maximum balance and safety, especially during fast, continuous operations.

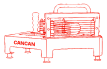

Made of Stainless Steel



Sharp Serrated Blades



Knife Cassette



Handle



Special Suction Feet



Table Support Plate



Hand Guard Shield

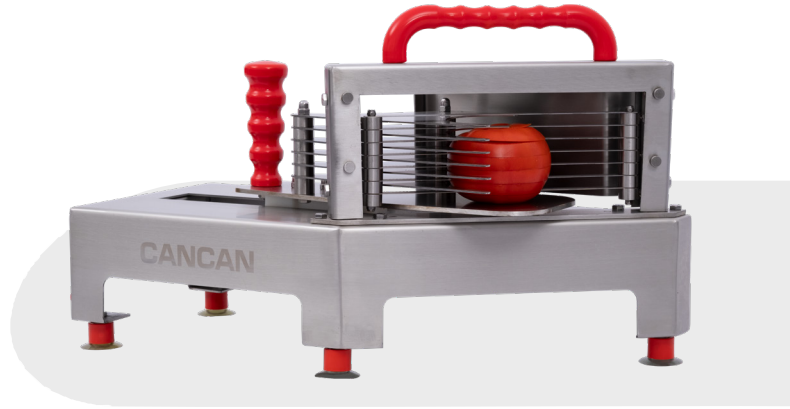

TOMATO

Blade Options



1302-1
5 mm



1302-2
7 mm



1302-3
10 mm

Technical Specifications

PRODUCT NAME	PRODUCT CODE	MAXIMUM TOMATO DIAMETER	DIMENSIONS	WEIGHT
TOMATO SLICER	1302	9 cm	50x22x30 cm	9 kg



1308

Small Size Tomato Slicer

The Small Size Tomato Slicer is a preferred slicer for industrial kitchens in hotels, cafes, and restaurants. Thanks to its serrated blades, it easily slices hard or even unripe tomatoes while preserving their freshness and flavor. Its special structure increases kitchen efficiency, while its ergonomic design ensures maximum performance even in small spaces.

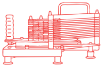

Made of Stainless Steel



Sharp Serrated Blades



Knife Cassette



Ergonomic Handle



Special Suction Feet



Easy To Use and Clean

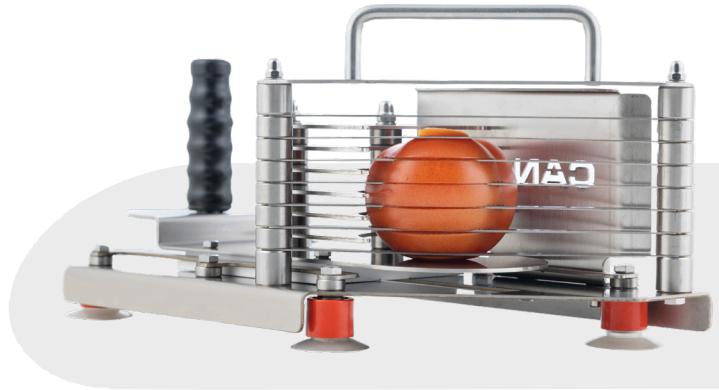

TOMATO

Blade Options

1308-1
5 mm1308-2
7 mm1308-3
10 mm

Technical Specifications



PRODUCT NAME	PRODUCT CODE	MAXIMUM TOMATO DIAMETER	DIMENSIONS	WEIGHT
SMALL SIZE TOMATO SLICER	1308	9,5 cm	37x16x17 cm	3,70 kg



1306

Practical Coring Spoon

The Practical Coring Spoon allows you to effortlessly remove tomato stems and strawberry tops with a single motion. It makes kitchen tasks easier by helping prepare fresh products quickly and effectively in both home and industrial kitchens.

-  Made of Stainless Steel
-  Minimal Error Rate
-  Comfortable Grip





Technical Specifications

PRODUCT NAME	PRODUCT CODE	DIMENSIONS	WEIGHT
PRACTICAL CORING SPOON	1306	2,5x1,5x12 cm	10 gr

1307

Practical Walnut Opener

The compactly designed Practical Walnut Opener is a practical and safe solution for effortlessly cracking hard-shelled walnuts. Its adaptable shape fits all walnut sizes, helping break the shell easily without shattering the inner part. It saves time and energy while delivering the natural flavor of walnuts to your table.

-  Made of Stainless Steel
-  Practical And Fast
-  Comfortable Grip



Technical Specifications

PRODUCT NAME	PRODUCT CODE	DIMENSIONS	WEIGHT
PRACTICAL WALNUT OPENER	1307	5x0,1x5 cm	10 gr

1313

Cheese Slicer

The Cheese Slicer, used in industrial kitchens such as hotels, restaurants, and cafes, allows for effortless slicing of various cheeses and eggs. Thanks to its adjustable wire system, it offers three cutting thickness options: 5 mm, 7 mm, and 10 mm, delivering precise and uniform cuts. The removable slicing cassette and worktable make post-use cleaning fast and easy.



Made of Stainless Steel



Three Thickness Options



Ergonomic Design



Easy Cleaning



Special Suction Feet



Effortless Slicing With Excellent Results



CHEDDAR



CHEESE



SWITZERLAND
CHEESE



EGG

Blade Options



1313-1
5 mm



1313-2
7 mm



1313-3
10 mm

Technical Specifications

PRODUCT NAME	PRODUCT CODE	TABLE SIZE	DIMENSIONS	WEIGHT
CHEESE SLICER	1313	16,5x9,1 cm	23x48x40 cm	3,90 kg



1319

Onion Flowering Cutter

The patented-design Onion Flower Cutter slices onions into an attractive flower shape using specially sharpened precision blades. This special cut is ideal for creating visually appealing and delicious-looking onion flower snacks, especially popular in appetizer plates. It adds variety and style to your menu while delivering fast, uniform cuts that improve kitchen efficiency.



Made of Stainless Steel



Sharp Blades



Special Suction Feet



Manual Locking Pin



Sliding Structure Feature



Height Adjustment Attachment



Easy Cleaning

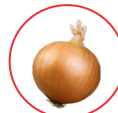
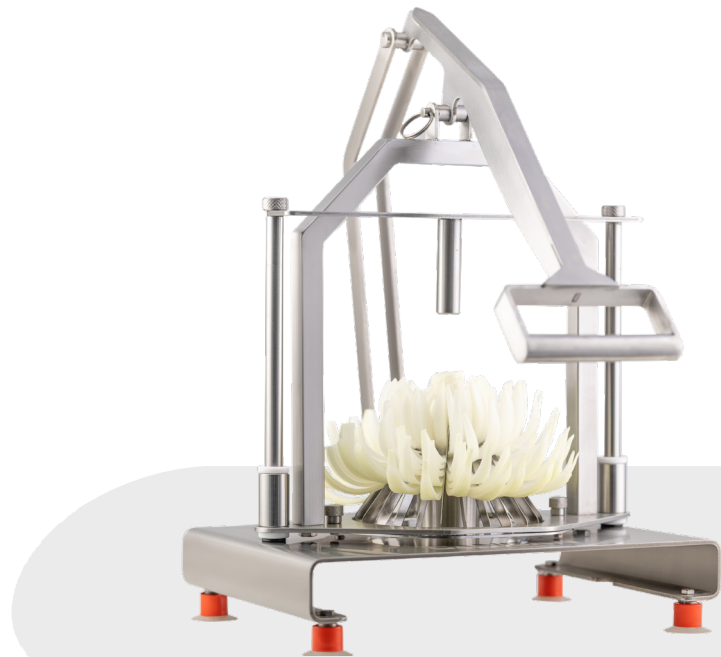

ONION



Technical Specifications

PRODUCT NAME	PRODUCT CODE	MAXIMUM ONION DIAMETER	DIMENSIONS	WEIGHT
ONION FLOWERING CUTTER	1319	10 cm	35x26x83 cm	9,3 kg



1321

Manual Potato Cutter

The Manual Potato Cutter, used in industrial kitchens, slices potatoes quickly and uniformly, meeting food standards with its stainless steel blade options to prepare fries in various sizes. The machine can be fixed securely to the counter or wall using its table or wall-mounting attachments. Its special pusher mechanism allows the product to be sliced evenly and effortlessly.



Made of Stainless Steel



Special Suction Feet



Blade And Pusher



Long Lifespan And Hygiene



Wall Mounting Attachment



POTATO

Blade Options

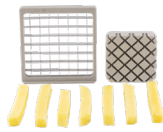

1321-1
6mm x 6mm

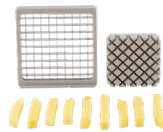

1321-2
10mm x 10mm

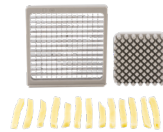

1321-3
13mm x 13mm

Technical Specifications

PRODUCT NAME	PRODUCT CODE	MAXIMUM POTATO DIAMETER	DIMENSIONS	WEIGHT
MANUAL POTATO CUTTER	1321	8 cm	20x43x41 cm	4,7 kg



1323

Vegetable & Fruit Peeler

Vegetable & Fruit Peeler, designed for use in hotels, restaurants, cafes, and industrial kitchens, peels fruit and vegetable skins efficiently and practically. Combining practicality and productivity, this machine accelerates and standardizes the peeling process.



Peels 8 Pieces Per Minute



Two Mode Options



Thin Peel Mode



Thick Peel Mode



Made of Stainless Steel



Adjustable Blade



ORANGE



GRAPEFRUIT



TOMATO



LEMON



LIME



APPLE



PEAR



Technical Specifications

PRODUCT NAME	PRODUCT CODE	DIMENSIONS	WEIGHT
VEGETABLE & FRUIT PEELER	1323	24x33x45 cm	11,3 KG
THINNER PEELS (SETTING 1)	THICKER PEELS (SETTING 2)	MAKSIMUM FRUIT/ VEGETABLE DIAMETER	POWER
8 unit/min.	4 unit/min.	PRODUCT CODE	35 WATT
CURRENT	VOLTAGE	FREQUENCY	IP
0,25 A	220-240 V	50-60 HZ	IPX4

1324

Manual Melon Cutting Tool

Manual Melon Cutting Tool, used in industrial kitchens, markets, and greengrocers, slices melons into equal portions with its flawless, sharp blades.

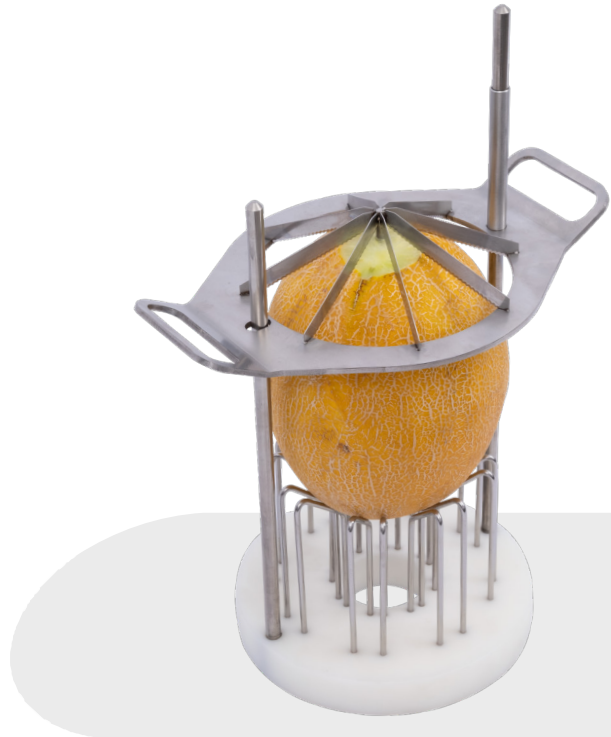

Stainless Steel Shaped Blades



Different Slicing Options



Easy Handles



Easy Cleaning



MELON

Blade Options



1324-1
4 Slices



1324-2
6 Slices



1324-3
8 Slices

Technical Specifications

PRODUCT NAME	PRODUCT CODE	MAXIMUM MELON DIAMETER	DIMENSIONS	WEIGHT
MANUAL MELON CUTTING TOOL	1324	15 cm	30x20x42 cm	2,5 kg

1332

Manual Watermelon Cutting Tool

The Manual Watermelon Cutting Tool, used in industrial kitchens, markets, and greengrocers, slices watermelons into equal portions with its flawless, sharp blades.

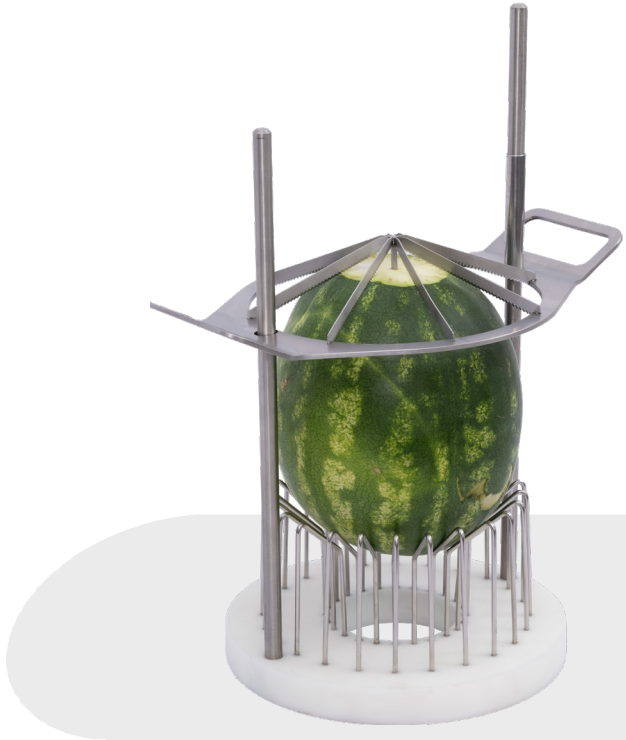

Stainless Steel Shaped Blades



Different Slicing Options



Easy Handles



Easy Cleaning



WATERMELON



MELON

Blade Options



1332-1
4 Slices



1332-2
6 Slices



1332-3
8 Slices

Technical Specifications

PRODUCT NAME	PRODUCT CODE	MAKSIMUM WATERMELON DIAMETER	DIMENSIONS	WEIGHT
MANUAL WATERMELON CUTTING TOOL	1332	28 cm	40x28x52 cm	4,5 kg



1327

Manual Watermelon Slicer

The Manual Watermelon Slicer makes it practical to slice watermelons and melons into equal pieces. This machine, which enhances presentation appeal, is used in markets, restaurants, cafes, hotels, and industrial kitchens. It helps increase serving quality by allowing customers to access fresh fruit quickly and efficiently.



Made of Stainless Steel



Easy Cutting



Special Non-Slip Feet



Easy Cleaning



WATERMELON



WATERMELON SLICES



MELON



15 mm

Technical Specifications

PRODUCT NAME	PRODUCT CODE	MAXIMUM LENGHT OF FRUIT	DIMENSIONS	WEIGHT
MANUAL WATERMELON SLICER	1327	37,5 cm x 7,5 cm	49x45x58 cm	16,7 kg



1325

Leaf Cutting

The Leaf Cutting is used in industrial kitchens such as hotels, restaurants, fast food outlets, and catering services. With a cutting thickness of 1.5 mm, this product's body is made entirely of stainless steel, meeting food standards. It creates visually appealing and elegant presentations by slicing fruits and vegetables into thin leaf-like forms.



Made of Stainless Steel



Ergonomic Crank Handle



Special Suction Feet



Easy Cleaning



POTATO



RADISH



ZUCCHINI



APPLE



Technical Specifications

PRODUCT NAME	PRODUCT CODE	MAXIMUM CUTTING DIAMETER/LENGTH	DIMENSIONS	WEIGHT
LEAF CUTTING	1325	15 cm/12 cm	29x21x20 cm	2,3 kg



0810

Pineapple Guillotine Cutter

The Pineapple Guillotine Cutter is designed to easily cut the tough corner parts of pineapples. Thanks to its adjustable blade system, it cuts pineapples of any size into equal pieces, accelerating preparation and saving time and labor in the kitchen. It is especially suitable for supermarket produce sections, industrial kitchens, and fruit processing areas. Its stainless steel body and easy-to-clean parts provide a hygienic and long-lasting solution.

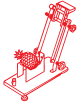

Made of Stainless Steel



Adjustable Blade Distance



Manual Locking Pin



Special Suction Feet



PINEAPPLE

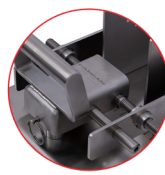

Technical Specifications

PRODUCT NAME	PRODUCT CODE	MAXIMUM PINEAPPLE DIAMETER	DIMENSIONS	WEIGHT
PINEAPPLE GUILLOTINE CUTTER	0810	15 cm	26x40x44 cm	5,8 kg



0801

Pineapple Peeler

The Pineapple Peeler is designed for hotels, restaurants, shopping centers, and greengrocers to peel pineapples quickly, safely, and efficiently. The peeler allows for one-touch peeling and coring, offering practical and hygienic use with its easily removable parts. All parts in contact with food are made of stainless steel and produced in compliance with food standards.



Polyethylene Feet



Safety Pin



Pusher Block



Pusher Block Pin



Optional Metal Stand



PINEAPPLE

Blade Options



74 mm



89 mm



95 mm



102 mm

Technical Specifications

PRODUCT NAME	PRODUCT CODE	MAXIMUM PINEAPPLE DIAMETER	DIMENSIONS	WEIGHT
PINEAPPLE PEELER	0801	15 cm	40x25x110 cm	12,2 kg



1326

Manual Pineapple Slicer

The Manual Pineapple Slicer is designed for use in supermarkets, hotels, restaurants, and greengrocers, making it easy to slice pineapples into equal parts. Its functional design and sharp blades ensure the slicing process is performed quickly and efficiently.



Made of Stainless Steel



Easy Cutting



Non-Slip Rubber Feet



Easy Cleaning



PINEAPPLE



PINEAPPLE SLICES

Technical Specifications

PRODUCT NAME	PRODUCT CODE	MAXIMUM PINEAPPLE DIAMETER	DIMENSIONS	WEIGHT
MANUAL PINEAPPLE SLICER	1326	12 cm	27x56x37 cm	8,4 kg



1423

Pineapple Trio

Specially designed for supermarkets and greengrocers, the Pineapple Trio combines the Pineapple Guillotine Cutter, Pineapple Peeler, and Manual Pineapple Slicer into a single unit, saving space and providing a practical solution for efficient use.

The set consists of three machines:



To cut the tough corners of the pineapple:

0810 Pineapple Guillotine Cutter



To peel and core in one motion:

0801 Pineapple Peeler



To slice into equal parts:

1326 Manual Pineapple Slicer



PINEAPPLE

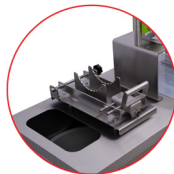

PRODUCT NAME	PRODUCT CODE	DIMENSIONS	WEIGHT
PINEAPPLE TRIO	1423	121x56x201 cm	72,4 kg

1315

Fruit Cutter

The Fruit Cutter is designed for hotels, restaurants, cafes, and industrial kitchens to slice various fruits quickly, evenly, and efficiently, saving time and offering practicality. This machine, used across a wide range from restaurant kitchens to self-service operations, makes chefs' workflows much more efficient.

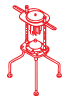

Made of Stainless Steel



Ergonomic Pusher Mechanism



Angled Design



Special Suction Feet



Easy Cleaning



APPLE



ORANGE



LEMON



LIME



KIWI



TOMATO



4 Slices



6 Slices



8 Slices



12 Slices



4 Slices



6 Slices



8 Slices



12 Slices

Core Remover Blade

Technical Specifications

PRODUCT NAME	PRODUCT CODE	MAXIMUM FRUIT DIAMETER	DIMENSIONS	WEIGHT
FRUIT CUTTER	1315	8,5 cm	47x35x65 cm	4,90 kg

1315

Fruit Cutter

Blade Options Details

*"8 different blade options for every use.
Choose the right blade for the slicing you need."*



1315-1
4 Slices

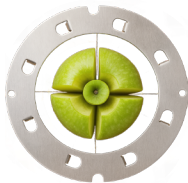

1315-5
4 Slices
Core Remover Blade



1315-2
6 Slices



1315-6
6 Slices
Core Remover Blade

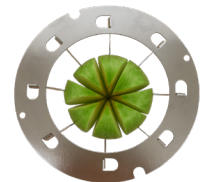

1315-3
8 Slices

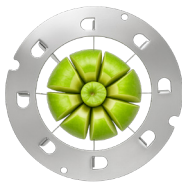

1315-7
8 Slices
Core Remover Blade

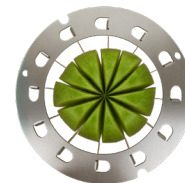

1315-3
8 Slices



1315-8
12 Slices
Core Remover Blade



1316

Lemon Cutter

The Lemon Cutter ensures lemons are sliced quickly, evenly, and precisely, delivering flawless results. Its special blade system allows you to cut lemons into quarters or slices, making it ideal for both cocktail presentation and kitchen use. With its ergonomic pusher mechanism, it slices effortlessly and hygienically in a single motion. It is an excellent choice for hotels, restaurants, and cafes aiming for fast and aesthetic service.



Made of Stainless Steel



Sharp Blades



Easy Cleaning



Ergonomic Pusher Mechanism



Special Suction Feet



Fast And Effective Use



LEMON



LIME



4 Slices



6 Slices



8 Slices



12 Slices



6 Half Slices



12 Half Slices

Technical Specifications

PRODUCT NAME	PRODUCT CODE	MAXIMUM LEMON DIAMETER	DIMENSIONS	WEIGHT
LEMON CUTTER	1316	8 cm	47x18x43 cm	3,4 kg



1316

Lemon Cutter Blade Options Details

*"6 different blade options for perfect versatility.
Choose the right blade for your needs."*

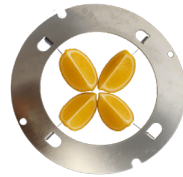

1316-1
4 Slices

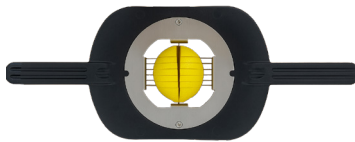
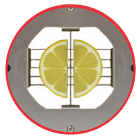

1316-6
12 Half Slices



1316-2
6 Slices

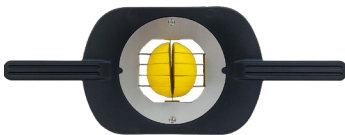
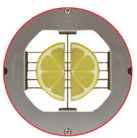

1316-5
6 Half Slices



1316-3
8 Slices



1316-4
12 Slices

1317

Combined Slicer

The Combined Slicer is designed for hotels, restaurants, cafes, and industrial kitchens to slice vegetables and fruits quickly, precisely, and evenly, saving time and offering practicality. This machine, used widely from restaurant kitchens to mass food service businesses, enhances the workflow of professional chefs. With its 13 interchangeable blades, it meets various slicing needs and allows slicing any vegetable or fruit at the desired thickness and shape.



Made of Stainless Steel



Sharp Blades



Ergonomic Pusher Mechanism



Special Suction Feet



Easy Cleaning

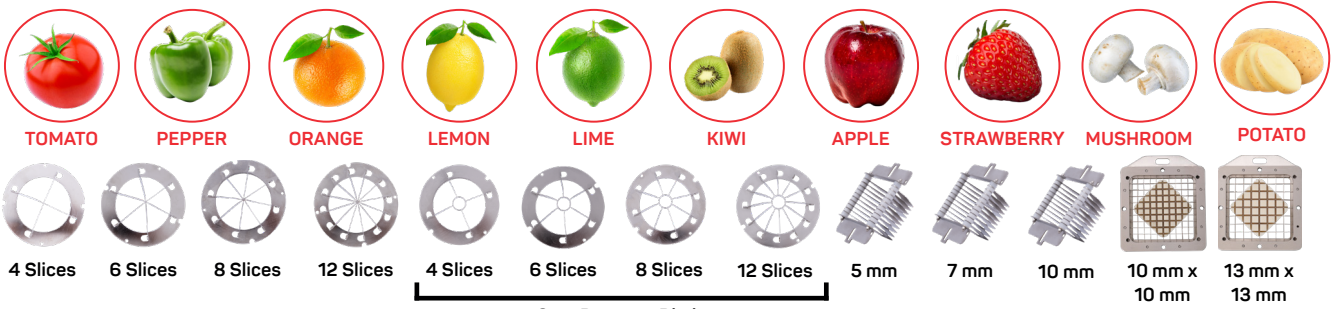

Core Remover Blade

Technical Specifications

PRODUCT NAME	PRODUCT CODE	MAXIMUM VEGETABLE-FRUIT DIAMETER	DIMENSIONS	WEIGHT
COMBINED SLICER	1317	9 cm	47x18x61 cm	7 kg

1317

Combined Slicer

Blade Options Details

*"13 different blade options for unlimited versatility.
The right slicing solution for every use."*

1317 D-13x13
13x13 mm

1317 W-4
4 Slices

1317 W-6
6 Slices

1317 W-8
8 Slices

1317 W-12
12 Slices

1317 W-4C
4 Slices
Core Remover
Blade

1317 W-6C
6 Slices
Core Remover
Blade

1317 W-8C
8 Slices
Core Remover
Blade

1317 W-12C
12 Slices
Core Remover
Blade

1317 D-10x10
10x10 mm

1317 S-10
10 mm

1317 S-7
7 mm

1317 S-5
5 mm

1318

Vertical Tomato Slicer

The Vertical Tomato Slicer is designed for hotels, restaurants, cafes, and industrial kitchens to slice tomatoes quickly, precisely, and evenly, saving time and increasing practicality in the kitchen. This machine, used across a wide range from restaurant kitchens to self-service operations, helps professional chefs make their workflow more efficient.

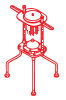

Made of Stainless Steel



Sharp Blades



Ergonomic Pusher Mechanism



Angled Design



Special Suction Feet



Easy Cleaning



TOMATO



CHERRY TOMATO



ORANGE



LEMON



LIME



KIWI



APPLE



STRAWBERRY



MUSHROOM

Blade Options



1318-1
5 mm



1318-2
7 mm



1318-3
10 mm

Technical Specifications

PRODUCT NAME	PRODUCT CODE	MAXIMUM VEGETABLE-FRUIT DIAMETER	DIMENSIONS	WEIGHT
VERTICAL TOMATO SLICER	1318	8,5 cm	47x35x66 cm	5,45 kg



1330

Pizza Slicer

The Pizza Slicer is a fast, hygienic, and practical device that ensures 4 or 8 equal slices, offering time-saving solutions for restaurants and industrial kitchens.



Made of Stainless Steel



Ergonomic Design



Special Handle Mechanism



Capacity



High Durability



Fast Slicing



PIZZA

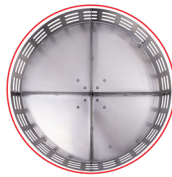

4 Slices

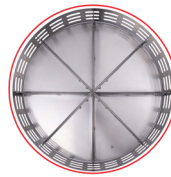

8 Slices

Technical Specifications

PRODUCT NAME	PRODUCT CODE	MAXIMUM PIZZA DIAMETER	DIMENSIONS	WEIGHT
PIZZA SLICER	1330	55 cm	60x85x57 cm	39 kg



1333

Sausage Slicer

The Sausage Slicer stands out with its ease of use, effortlessly slicing sausages. Its compact and portable design offers great convenience, and the suction feet keep it stable during use. The machine comes with two blade options (6 mm and 12 mm) and works with a compatible tray cover. Both the tray cover and blades are made entirely of stainless steel and can be easily detached and washed in the dishwasher.



Compact And Portable Design



Blade Options: 6 mm And 12 mm



Compatible Tray Cover



Special Suction Feet



Easy Cleaning



SAUSAGE



STRAWBERRY



BANANA



MUSHROOM

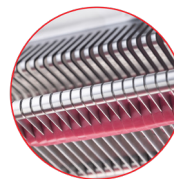
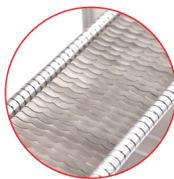

Technical Specifications

PRODUCT NAME	PRODUCT CODE	DIMENSIONS	WEIGHT
SAUSAGE SLICER	1333	25,5x20x31 cm	3 kg

1338

Sausage Slicer (Julienne Cut)

The Sausage Slicer (Julienne Cut) is designed to quickly, evenly, and aesthetically slice sausages into julienne form. Ideal for breakfast services, ready-to-eat production, and fast-food kitchens, this machine uses sharp blades to cut products into clean strips without crushing them. It offers standard and symmetrical slices, enhancing presentation quality and optimizing cooking time. With its practical use, easy-to-clean design, and sturdy body, it provides significant time and labor savings in suitable kitchen environments.

NEW!



Made of Stainless Steel



Compact And Portable Design



Easy Cleaning



Detachable Parts



SAUSAGE



Technical Specifications

PRODUCT NAME	PRODUCT CODE	DIMENSIONS	WEIGHT
SAUSAGE SLICER (JULIENNE CUT)	1338	17x22x35 cm	1,5 kg



1335

Block Cheese Slicer

The Block Cheese Slicer effortlessly slices cheese into even thicknesses thanks to its wire system. Made entirely of stainless steel, its body offers superior durability and long lifespan. Its compact design ensures easy portability and practical use.



Compact And Portable Design



Customizable Slices



Easy Operation



Special Non-Slip Feet



Easy Cleaning



WHITE CHEESE



YELLOW CHEESE



BUTTER



Technical Specifications

PRODUCT NAME	PRODUCT CODE	DIMENSIONS	WEIGHT
BLOCK CHEESE SLICER	1335	34x17x24 cm	1,612 kg



1336

Rail Cheese Slicer

The Rail Cheese Slicer is designed to effortlessly cut the hardest and largest cheese blocks. Its wire cutting system slices cheese blocks cleanly and evenly, while the spring system allows cutting hard cheeses without extra force. The non-slip rubber feet keep the machine stable during cutting, ensuring safe use. Made entirely of stainless steel, it offers superior durability and long lifespan, and is extremely easy to clean.



Compact And Portable Design



Wire Cutting



Suitable Cutting For Hard And Large Cheeses



Special Non-Slip Feet



Easy Cleaning



WHITE CHEESE



YELLOW CHEESE



OLD CHEESE



Technical Specifications

PRODUCT NAME	PRODUCT CODE	DIMENSIONS	WEIGHT
RAIL CHEESE SLICER	1336	30x40x15 cm	5,056 kg



1334

Spiral Twister Potato Cutter

The Spiral Twister Potato Cutter slices potatoes into spiral shapes, creating visually appealing and uniform cuts. It's an ideal product for fast-food restaurants, street food vendors, and festival stands. Thanks to its sharp blades, it allows the potato to be easily cut and placed onto a stick, ready for presentation. This slicing method not only enhances presentation but also shortens cooking time, offering a practical and efficient preparation process.



Made of Stainless Steel



Potato Holding Feature



Special Suction Feet



Fast And Practical Slicing



Easy Operation



POTATO



CUCUMBER



RADISH



Technical Specifications

PRODUCT NAME	PRODUCT CODE	DIMENSIONS	WEIGHT
SPIRAL TWISTER POTATO CUTTER	1334	12x50x22,5 cm	1,742 kg



1340

Spiral Curly Fry Cutter

The Spiral Curly Fry Cutter is a highly efficient and practical device capable of producing spiral cuts. Its easy-to-use handle and threaded shaft enable smooth cutting without the need for extra force. The latch on the threaded shaft allows the handle to be retracted in a single motion when the process is complete, saving time. Its compact and portable design adapts to various workspaces. The fixing blade holds the product steady during cutting, while the removable cutting head can be easily washed in a dishwasher. Additionally, the base plate can be detached if desired, allowing it to be mounted on any table.

NEW!

Made of Stainless Steel



Handle And Threaded Shaft



Potato Holding Feature



Removable Base Tray



POTATO



Technical Specifications

PRODUCT NAME	PRODUCT CODE	DIMENSIONS	WEIGHT
SPIRAL CURLY FRY CUTTER	1340	20x50x26 cm	3,170 kg



1701

Butter Roller

The Butter Roller, used in hotels, restaurants, cafes, and industrial kitchens, applies oils (including butter, olive oil, and spiced sauces) to bread in a controlled manner, preventing excess use while enhancing flavor. It offers efficient, hygienic, and cost-saving application for a wide range of kitchen operations.



Made of Stainless Steel



Time And Cost Efficiency



Effortless Use



Practical And Fast



Easy Cleaning



Designed with an 18 cm width, the Butter Roller can comfortably accommodate a standard bread.



BURGER BUN

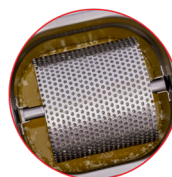

Technical Specifications

PRODUCT NAME	PRODUCT CODE	DIMENSIONS	WEIGHT
BUTTER ROLLER	1701	18x16x11 cm	0,55 kg



1705

Butter Roller XL

The Butter Roller XL, designed for use in hotels, restaurants, cafes, and industrial kitchens, applies butter, olive oil, and even seasoned sauces in a controlled manner across a wide range of breads. This enhances flavor while preventing waste, offering both efficiency and precision.



Made of Stainless Steel



Time And Cost Efficiency



Effortless Use



Practical And Fast



Easy Cleaning



Designed with an 38 cm width, the Butter Roller can comfortably accommodate two standard bread.



BURGER BUN



Technical Specifications

PRODUCT NAME	PRODUCT CODE	DIMENSIONS	WEIGHT
BUTTER ROLLER XL	1705	32,5x18x12 cm	1,225 kg



1706

Smash Burger Press (Circular)

The Smash Burger Press allows you to press burger patties in one swift motion, ensuring rapid caramelization and even cooking. Offered with 12 cm, 14 cm, and 16 cm diameter options, its stainless steel base and ergonomic handle deliver consistent results in both professional kitchens and home chef environments. Its sturdy body, heat-resistant structure, and easy-to-clean surface make kitchen workflows more efficient.

NEW!

Stainless Steel Base



Ergonomic Handle



Circular Pressing Surface



Easy To Clean



BURGER PATTY



Technical Specifications

PRODUCT NAME	PRODUCT CODE	DIMENSIONS	WEIGHT	DIAMETER
SMASH BURGER (CIRCULAR)	1706	12,5x12x8 cm	0,45 kg	12 cm 14 cm 16 cm

1707

Smash Burger Press (Square)

The Smash Burger Press enables you to press burger patties in one swift motion, ensuring quick caramelization, even cooking, and consistent results. Featuring a stainless steel wide pressing surface and an ergonomic handle, it delivers reliable performance in both professional kitchens and home chef use. Its sturdy body, heat-resistant structure, and easy-to-clean surface make kitchen workflows more efficient.



Stainless Steel Base



Ergonomic Handle



Wide Pressing Surface



Easy To Clean

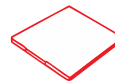

16 cm x 14 cm



BURGER PATTY



Technical Specifications

PRODUCT NAME	PRODUCT CODE	DIMENSIONS	WEIGHT
SMASH BURGER (SQUARE)	1707	16x14x8 cm	0,67 kg



1709

Iron Steak Weight

The Iron Steak Weight flattens meat in a single motion, ensuring fast caramelization and even cooking. Its solid cast iron body retains heat exceptionally well, delivering consistent results in both professional kitchens and at home. The ergonomic handle provides a comfortable grip, while its durable structure guarantees long-lasting performance. With an easy-to-clean surface, it streamlines your kitchen workflow and elevates your grilling and steak-searing experience.



Cast Iron Body



Ergonomic Handle



Wide Pressing Surface



Easy To Clean



BURGER PATTY



STEAK



Technical Specifications

PRODUCT NAME	PRODUCT CODE	DIMENSIONS	WEIGHT
IRON STEAK WEIGHT	1709	20x10x10 cm	1 kg



1708

Tamper

The Coffee Tamper ensures a flat and homogeneous coffee bed during espresso preparation, allowing water to pass evenly through the coffee for optimal extraction. Offered in 51 mm, 53 mm, 55 mm, and 58 mm diameter options, its stainless steel base and ergonomic handle provide the consistent tamping pressure sought by both home baristas and busy coffee shops. Balanced weight distribution and a non-slip grip surface create the ideal professional base for maximizing flavor.



Stainless Steel Base



Ergonomic Handle



Balanced Weight Distribution



Micro-Smooth Surface



Easy To Clean



COFFEE



Technical Specifications

PRODUCT NAME	PRODUCT CODE	DIMENSIONS	WEIGHT	DIAMETER
TAMPER	1708	9,15 cm	0,308 kg	51 mm 53 mm 55 mm 58 mm

1337

Block Cheese Slicer XL

Thanks to its wire system, the block cheese slicer effortlessly slices cheese by lowering the wire from top to bottom. It delivers high performance even with hard cheeses. The specially designed cutting mechanism ensures clean, even slices without applying excessive force or breaking the cheese. It is ideal for use in both professional kitchens and high-volume service areas.



Compact And Portable Design



Suitable Cutting For Hard And Large Cheeses



Wire Cutting



Special Non-Slip Feet



Easy Cleaning



WHITE CHEESE



YELLOW CHEESE



OLD CHEESE



BUTTER



Technical Specifications

PRODUCT NAME	PRODUCT CODE	DIMENSIONS	WEIGHT
BLOCK CHEESE SLICER XL	1337	48x45x49 cm	4,2 kg



Preparation Equipments

Fruit and Vegetable Processing Equipments (Industrial Type)





1305

Pneumatic Potato Cutter

The Pneumatic Potato Cutter slices potatoes quickly and precisely, reducing labor effort, saving time, and ensuring uniform, flawless cuts to increase kitchen efficiency. Thanks to its sharp stainless steel blades, it produces equal-sized potato slices effortlessly at the desired thickness.



Stainless Steel Blades



High Technology



Lid With Safety Switch



Ergonomic Lid Handle



Air Socket



Special Non-Slip Feet



POTATO



CUCUMBER



CARROT

Blade Options

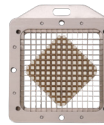
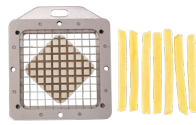
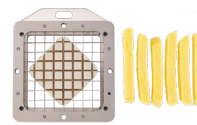
1305-1
6x6 mm1305-2
10x10 mm1305-3
13x13 mm

Technical Specifications

PRODUCT NAME	PRODUCT CODE	DIMENSIONS	WEIGHT
PNEUMATIC POTATO CUTTER	1305	70x27x28 cm	19,2 kg
MAXIMUM POTATO DIAMETER	MAXIMUM WORKING FORCE	WORKING PRESSURE	MAXIMUM SLICING LENGTH
8 cm	1500 N	6-8 bar	19 cm



1342

Electrical Potato Cutter

Electrical Potato Cutter is designed to slice potatoes quickly, evenly, and precisely. Powered by a strong electric motor, it operates with high efficiency without the need for manual force or air connection. Its ergonomic design and sharp stainless steel blades allow for uniform cuts without deforming the potatoes. The patented design makes it unique in its category. It is ideal for intensive use in restaurants, fast food outlets, and industrial kitchens.



Patented Design



Stainless Steel Blades



Start/Stop & Safety Button



Lid With Safety Switch



Ergonomic Lid Handle



High-Tech Motor



Special Non-Slip Feet



POTATO



CUCUMBER



CARROT

Blade Options

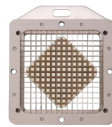
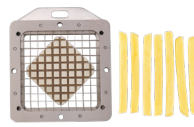
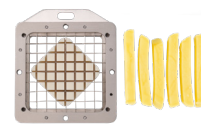
1342-1
6x6 mm1342-2
10x10 mm1342-3
13x13 mm

Technical Specifications

PRODUCT NAME	PRODUCT CODE	DIMENSIONS	WEIGHT	MAXIMUM POTATO DIAMETER
ELECTRICAL POTATO CUTTER	1342	94x30x44 cm	44,5 kg	8 cm
MAXIMUM SLICING LENGTH	VOLTAGE	FREQUENCY	HOURLY SLICING CAPACITY (UNITS)	HOURLY SLICING CAPACITY (KG)
19 cm	220 - 230 V	50 - 60 Hz	960	75 kg



1309

Pneumatic Melon Cutter

The Pneumatic Melon Cutter uses air pressure to slice melons of various sizes precisely and effortlessly, delivering clean cuts with minimal labor. From large-scale production facilities to catering operations, it offers exceptional efficiency and high productivity with less workforce.



Made of Stainless Steel



Fast And Even Slicing



Ease Of Use



Advanced Air System



Durable Structure



12 Slices



MELON

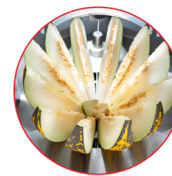
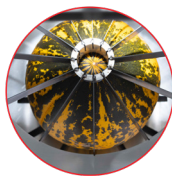

Technical Specifications

PRODUCT NAME	PRODUCT CODE	DIMENSIONS	WEIGHT
PNEUMATIC MELON CUTTER	1309	67x54x215 cm	70 kg
MAXIMUM SLICING LENGTH	MAXIMUM SLICING DIAMETER	MAXIMUM WORKING FORCE	WORKING PRESSURE
35 cm	22 cm	1500 N	6-8 bar



1310

Pneumatic Watermelon Cutter

The Pneumatic Watermelon Cutter uses air pressure to slice watermelons of various sizes precisely and effortlessly, delivering clean cuts. From large-scale production facilities to catering operations, it offers unmatched efficiency and high productivity with less workforce.



Made of Stainless Steel



Double Safety Button



Ease Of Use



Advanced Air System



Two Blade Options (Cube Cutting/
Circular Cutting)

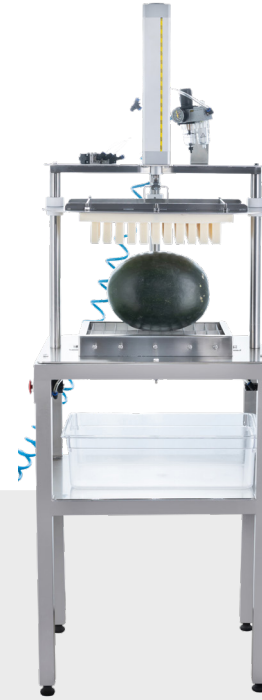

WATERMELON



MELON

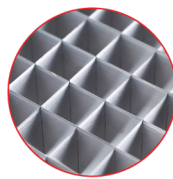
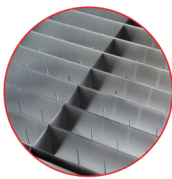

Technical Specifications

PRODUCT NAME	PRODUCT CODE	DIMENSIONS	WEIGHT
PNEUMATIC WATERMELON CUTTER	1310	65x50x180 cm	60 kg
MAXIMUM SLICING LENGTH	MAXIMUM SLICING DIAMETER	MAXIMUM WORKING FORCE	WORKING PRESSURE
28 cm	26 cm	1500 N	6-8 bar

0809

Pneumatic Pineapple Peeler with Stand

The Pneumatic Pineapple Peeling Machine simplifies the time- and labor-intensive pineapple peeling process with an advanced air pressure system. This innovative solution provides fast and consistent peeling performance, saving both time and labor costs. Thanks to its pneumatic technology, which adapts to the shape and size of the fruit, each pineapple is perfectly peeled every time. From large-scale production facilities to catering operations, it offers exceptional efficiency and high productivity with less workforce. Its brake-equipped wheels on the portable mobile stand make it easy to move the unit.



Made of Stainless Steel



Double Safety Button



One-Step Effective Result



Advanced Air System



Technical Specifications

PRODUCT NAME	PRODUCT CODE	DIMENSIONS	WEIGHT
PNEUMATIC PINEAPPLE PEELING MACHINE	0809	140x45x180 cm	60 kg
MAXIMUM SLICING LENGTH	MAXIMUM SLICING DIAMETER	MAXIMUM WORKING FORCE	WORKING PRESSURE
25 cm	15 cm	1500 N	6-8 bar



Preparation Equipments

Electrical & Manual Can Openers

CANCAN® Can Openers offer safe and fast use in kitchens with their durable structure and ergonomic design. Thanks to their stainless steel materials, they provide long-lasting performance and fully comply with hygiene standards. With both manual and electric models, CANCAN® offers solutions for various needs, catering to a wide range of applications from industrial kitchens to catering services. Their easy-to-use mechanisms reduce workload, making preparation processes more efficient and practical.



0302

Professional Type Manual Can Opener

The professional type manual can opener provides great convenience to users by safely and hygienically opening cans, whether large or small, in places such as professional catering, industrial kitchens, hospitals, and cafeterias.



NSF Certified



Turning Handle



Helical Gear



Stainless-Steel Blade



Stainless-Steel Food



Stainless-Steel Fixing Aparatus



Technical Specifications

PRODUCT NAME	PRODUCT CODE	DAILY CAPACITY	WEIGHT	PROFILE HEIGHT	CAN SIZES
PROFESSIONAL TYPE MANUAL CAN OPENER	0302	40 - 65 CANS	2 kg	63 cm	MAXIMUM 55 cm



0303

Stainless Manual Can Opener

The Stainless Manual Can Opener provides great convenience to users by offering the ability to safely and hygienically open cans, regardless of size, in places such as professional catering services, industrial kitchens, hospitals, and cafeterias.



NSF Certified



Turning Handle



Helical Gear



Stainless-Steel Blade



Stainless-Steel Food



Stainless-Steel Fixing Aparatus



Technical Specifications

PRODUCT NAME	PRODUCT CODE	DAILY CAPACITY	WEIGHT	PROFILE HEIGHT	CAN SIZES
STAINLESS MANUAL CAN OPENER	0303	65 - 100 CANS	3 kg	63 cm	MAXIMUM 55 cm

0702

Professional Type Electrical Can Opener

Circle Cut

The fully stainless-steel professional type electrical can opener is designed to open cans such as cheese, olives, and paint tins in industrial kitchens quickly and without requiring much force, thanks to its rotating helix gear that prevents slipping and skipping, stainless-steel blade, and special design. The Professional Type Electrical Can Opener helps companies ensure workplace safety by reducing the risk of potential work accidents.



-  Handle
-  Brake Lever
-  Helical Gear
-  Stainless-Steel Blade
-  Stainless-Steel Arm
-  Stainless-Steel Support Shaft
-  Magnetic Holding Shaft
-  Rotating Table



Technical Specifications

PRODUCT NAME	PRODUCT CODE	DIMENSIONS	WEIGHT	CAN OPENING CAPACITY
PROFESSIONAL TYPE ELECTRICAL CAN OPENER	0702	30x49x82 cm	30 kg	3-8 Adet/dk
CAN SIZES	POWER	VOLTAGE	FREQUENCY	
6 cm - 35 cm	0,18 kW	220 - 240 V	50 - 60 Hz	

0703

Professional Type Electrical Can Opener

Circle-Square Cut

The fully stainless-steel professional type electrical can opener is designed to open industrial kitchen cans such as cheese, olives, and paint tins quickly and without requiring much force, thanks to its rotating helix gear that prevents slipping and skipping, its stainless-steel blade, and its special design. The Professional Type Electrical Can Opener helps companies ensure workplace safety by reducing the risk of potential work accidents.



Handle



Brake Lever



Helical Gear



Stainless-Steel Blade



Stainless-Steel Arm



Stainless-Steel Support Shaft



Magnetic Holding Shaft



Rotating Table



Moving Table



Technical Specifications

PRODUCT NAME	PRODUCT CODE	DIMENSIONS	WEIGHT	CAN OPENING CAPACITY
PROFESSIONAL TYPE ELECTRICAL CAN OPENER	0703	49x59x82 cm	30 kg	3-8 Adet/dk
CAN SIZES	POWER	VOLTAGE	FREQUENCY	
6 cm - 35 cm	0,18 kW	220 - 240 V	50 - 60 Hz	

WASHING EQUIPMENT





Washing Equipment Pre-Rinse Faucets

CANCAN® Washing Equipments are designed for maximum hygiene and efficiency in industrial kitchens. With their stainless-steel construction, they offer long-lasting use while their ergonomic designs speed up workflows and ensure water savings. Offering both compact and large-capacity models for various kitchen needs, they make it easy to hygienically clean vegetables, fruits, and kitchen equipment. With CANCAN®, washing processes become cleaner, more practical, and safer.





Washing Equipments

Pre-Rinse Faucets

COMPARISON CHART

Pre-Rinse Faucets are used in industrial kitchens, industrial dishwashing machines, vegetable and fruit washing units in the pre-washing stage.



MT01
Sink Mounted
Pre-Rinse Faucet



MT02
Sink Mounted
Pre-Rinse Faucet
with Intermediate Tap



MT03
Wall Mounted
Pre-Rinse Faucet



Cataphoresis Coated Spring



Hose



MT04

Wall Mounted
Pre-Rinse Faucet
with Intermediate Tap

S Pipe

Intermediate Tap



MT05

Mini Size Sink
Mounted Pre-Rinse
Faucet



MT06

Mini Size Sink
Mounted
Pre-Rinse Faucet
with Intermediate Tap

0501

MT01 Sink Mounted Pre-Rinse Faucet

Sink-mounted pre-rinse faucets are used in industrial kitchens, industrial dishwashing machines, and vegetable-fruit washing units during the pre-wash stage.



Brass Material with Chrome Plating



Stainless Steel Pipes



360° Rotating Handle



Water Outlet Strainer



Hot and Cold Water Inlet



Cataphoresis Coated Spring



Water Pressure Adjustment



Water and Detergent Savings



Technical Specifications

PRODUCT NAME	PRODUCT CODE	DIMENSIONS	WEIGHT
MT01 SINK MOUNTED PRE-RINSE FAUCET	0501	16x55x114 cm	4,4 kg

0502

MT02 Sink Mounted Pre-Rinse Faucet

with Intermediate Tap

Sink-mounted pre-rinse faucets are used in industrial kitchens, industrial dishwashing machines, and vegetable-fruit washing units during the pre-wash stage.



Brass Material with Chrome Plating



Stainless Steel Pipes



360° Rotating Handle



Water Outlet Strainer



Hot and Cold Water Inlet



Cataphoresis Coated Spring



Water Pressure Adjustment



Water and Detergent Savings



Technical Specifications

PRODUCT NAME	PRODUCT CODE	DIMENSIONS	WEIGHT
MT02 SINK MOUNTED PRE-RINSE FAUCET WITH INTERMEDIATE TAP	0502	16x56x114 cm	4,8 kg

0503

MT03 Wall Mounted Pre-Rinse Faucet

Wall-mounted pre-rinse faucets are used in industrial kitchens, industrial dishwashing machines, and vegetable-fruit washing units during the pre-wash stage.



Brass Material with Chrome Plating



Stainless Steel Pipes



360° Rotating Handle



Water Outlet Strainer



Hot and Cold Water Inlet



Cataphoresis Coated Spring



Water Pressure Adjustment



Water and Detergent Savings



Technical Specifications

PRODUCT NAME	PRODUCT CODE	DIMENSIONS	WEIGHT
MT03 WALL MOUNTED PRE-RINSE FAUCET	0503	22x51x114 cm	4,2 kg

0504

MT04 Wall Mounted Pre-Rinse Faucet

with Intermediate Tap

Wall-mounted pre-rinse faucets are used in industrial kitchens, industrial dishwashing machines, and vegetable-fruit washing units during the pre-wash stage.



Brass Material with Chrome Plating



Stainless Steel Pipes



360° Rotating Handle



Water Outlet Strainer



Hot and Cold Water Inlet



Cataphoresis Coated Spring



Water Pressure Adjustment



Water and Detergent Savings



Technical Specifications

PRODUCT NAME	PRODUCT CODE	DIMENSIONS	WEIGHT
MT04 WALL MOUNTED PRE-RINSE FAUCET WITH INTERMEDIATE TAP	0504	22x51x114 cm	4,9 kg

0505

MT05 Mini Size Sink Mounted Pre-Rinse Faucet

Mini Size Pre-Rinse Faucets are used in homes, industrial kitchens, industrial dishwashers, and vegetable and fruit washing units during the pre-wash stage.



Brass Material with Chrome Plating



Stainless Steel Pipes



360° Rotating Handle



Water Outlet Strainer



Hot and Cold Water Inlet



Cataphoresis Coated Spring



Water Pressure Adjustment



Water and Detergent Savings



Technical Specifications

PRODUCT NAME	PRODUCT CODE	DIMENSIONS	WEIGHT
MT05 MINI SIZE SINK MOUNTED PRE-RINSE FAUCET	0505	16x45x58 cm	3,2 kg

0506

MT06 Mini Size Sink Mounted Pre-Rinse Faucet

with Intermediate Tap

Mini Size Pre-Rinse Faucets with Intermediate Taps are used in homes, industrial kitchens, industrial dishwashers, and vegetable and fruit washing units during the pre-wash stage.



Brass Material with Chrome Plating



Stainless Steel Pipes



360° Rotating Handle



Water Outlet Strainer



Hot and Cold Water Inlet



Cataphoresis Coated Spring



Water Pressure Adjustment



Water and Detergent Savings



Technical Specifications

PRODUCT NAME	PRODUCT CODE	DIMENSIONS	WEIGHT
MT06 MINI SIZE SINK MOUNTED PRE-RINSE FAUCET WITH INTERMEDIATE TAP	0506	20x45x58 cm	3,8 kg



Washing Equipment **Pre-Rinse Faucets Deluxe Series**

CANCAN® Deluxe Pre-Rinse Faucets are designed to enhance hygiene and efficiency in industrial kitchens. Their stainless-steel construction ensures long-lasting use, while the ergonomic design provides water savings and ease of operation. With compact and standard models, they make the effective pre-washing of vegetables, fruits, and equipment practical and safe.



0507

MT01 Deluxe Sink Mounted Pre-Rinse Faucet

Sink-mounted pre-rinse faucets are used in industrial kitchens, industrial dishwashing machines, and vegetable-fruit washing units during the pre-wash stage.



Brass Material with Chrome Plating



Stainless Steel Pipes



360° Rotating Handle



Water Outlet Strainer



Hot and Cold Water Inlet



Stainless Steel Spring



Water Pressure Adjustment



Water and Detergent Savings



Technical Specifications

PRODUCT NAME	PRODUCT CODE	DIMENSIONS	WEIGHT
MT01 DELUXE SINK MOUNTED PRE-RINSE FAUCET	0507	16x56x113 cm	4,7 kg

0508

MT02 Deluxe Sink Mounted Pre-Rinse Faucet

with Intermediate Tap

Sink-mounted pre-rinse faucets are used in industrial kitchens, industrial dishwashing machines, and vegetable-fruit washing units during the pre-wash stage.



Brass Material with Chrome Plating



Stainless Steel Pipes



360° Rotating Handle



Water Outlet Strainer



Hot and Cold Water Inlet



Stainless Steel Spring



Water Pressure Adjustment



Water and Detergent Savings



Technical Specifications

PRODUCT NAME	PRODUCT CODE	DIMENSIONS	WEIGHT
MT02 DELUXE SINK MOUNTED PRE-RINSE FAUCET WITH INTERMEDIATE TAP	0508	16x56x113 cm	5,4 kg

0512

MT03 Deluxe Wall Mounted Pre-Rinse Faucet

Wall-mounted pre-rinse faucets are used in industrial kitchens, industrial dishwashing machines, and vegetable-fruit washing units during the pre-wash stage.



Brass Material with Chrome Plating



Stainless Steel Pipes



360° Rotating Handle



Water Outlet Strainer



Hot and Cold Water Inlet



Stainless Steel Spring



Water Pressure Adjustment



Water and Detergent Savings



Technical Specifications

PRODUCT NAME	PRODUCT CODE	DIMENSIONS	WEIGHT
MT03 DELUXE WALL MOUNTED PRE-RINSE FAUCET	0512	22x50x113 cm	4 kg

0513

MT04 Deluxe Wall Mounted Pre-Rinse Faucet

with Intermediate Tap

Wall-mounted pre-rinse faucets are used in industrial kitchens, industrial dishwashing machines, and vegetable-fruit washing units during the pre-wash stage.



Brass Material with Chrome Plating



Stainless Steel Pipes



360° Rotating Handle



Water Outlet Strainer



Hot and Cold Water Inlet



Stainless Steel Spring



Water Pressure Adjustment



Water and Detergent Savings



Technical Specifications

PRODUCT NAME	PRODUCT CODE	DIMENSIONS	WEIGHT
MT04 DELUXE WALL MOUNTED PRE-RINSE FAUCET WITH INTERMEDIATE TAP	0513	22x50x113 cm	5 kg

0509

MT05 Deluxe Mini Size Sink Mounted

Pre-Rinse Faucet

Mini Size Pre-Rinse Faucets are used in homes, industrial kitchens, industrial dishwashers, and vegetable and fruit washing units during the pre-wash stage.



Brass Material with Chrome Plating

Stainless Steel Pipes

360° Rotating Handle

Water Outlet Strainer

Hot and Cold Water Inlet

Stainless Steel Spring

Water Pressure Adjustment

Water and Detergent Savings



Technical Specifications

PRODUCT NAME	PRODUCT CODE	DIMENSIONS	WEIGHT
MT05 DELUXE MINI SIZE SINK MOUNTED PRE-RINSE FAUCET	0509	16x45x56,5 cm	3,5 kg

0510

MT06 Deluxe Mini Size Sink Mounted

Pre-Rinse Faucet with Intermediate Tap

Mini Size Pre-Rinse Faucets with Intermediate Taps are used in homes, industrial kitchens, industrial dishwashers, and vegetable and fruit washing units during the pre-wash stage.



- Brass Material with Chrome Plating
- Stainless Steel Pipes
- 360° Rotating Handle
- Water Outlet Strainer
- Hot and Cold Water Inlet
- Stainless Steel Spring
- Water Pressure Adjustment
- Water and Detergent Savings



Technical Specifications

PRODUCT NAME	PRODUCT CODE	DIMENSIONS	WEIGHT
MT06 DELUXE MINI SIZE SINK MOUNTED PRE-RINSE FAUCET WITH INTERMEDIATE TAP	0510	18x45x56,5 cm	4,2 kg



Washing Equipment **Sink Mount Pot Filler**





0511

Sink Mount Pot Filler

The Sink Mount Pot Filler is designed to quickly fill large pots in industrial kitchens without needing to lift them off the stove. Made from 304 stainless steel, it features a 180° rotating dual-jointed arm and a ceramic cartridge valve that opens and closes with a quarter turn, providing maximum hygiene, durability, and user comfort. It connects only to the cold water line; its high flow rate increases service speed, while the ergonomic handle allows precise control of water flow at the point of use.



Stainless Steel Body



180° Rotating Movable Spout



Full Open / Close with One Motion



Easy Cleaning & Maintenance

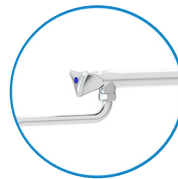

Technical Specifications

PRODUCT NAME	PRODUCT CODE	DIMENSIONS	WEIGHT
SINK MOUNT POT FILLER	0511	6,5x78x93 cm	2,8 kg



Washing Equipment **Retractable Models**





0905

Retractable Pre-Rinse Faucet

with Reel Hose (2mt)

The 2 m Retractable Pre-Rinse Faucet is designed exclusively for connection to industrial ovens. It provides an effective pre-rinse solution for cleaning inside and around the oven. Thanks to its durable body and flexible hose, it is suitable for heavy-duty use. It ensures a hygienic and practical cleaning experience.



2m Hose Reel Capacity



Wall Mount Feature



Adjustable Hose Outlet



Polyamide-Bearing Reel Hub



Stainless Steel Outer Body



10-30 Bar Pressure-Resistant Hose



Technical Specifications

PRODUCT NAME	PRODUCT CODE	DIMENSIONS	WEIGHT
RETRACTABLE PRE-RINSE FAUCET WITH REEL HOSE (2MT)	0905	10x23x23 cm	3 kg

0901

Retractable Pre-Rinse Faucet

with Reel Hose (6mt)

The 6m Retractable Pre-Rinse Faucet is used in industrial kitchens, food preparation areas, mass food production facilities, industrial dishwashers, vegetable-fruit washing sinks, and industrial ovens as a pre-rinse spray. Its robust structure and flexible hose make it suitable for heavy use, providing practicality and hygiene during cleaning processes.



6m Hose Reel Capacity



Wall Mount Feature



Adjustable Hose Outlet



Polyamide-Bearing Reel Hub



Stainless Steel Outer Body



10-30 Bar Pressure-Resistant Hose



Technical Specifications

PRODUCT NAME	PRODUCT CODE	DIMENSIONS	WEIGHT
RETRACTABLE PRE-RINSE FAUCET WITH REEL HOSE (6MT)	0901	12x40x40 cm	10 kg

0902

Retractable Pre-Rinse Faucet

with Reel Hose (10mt)

The 10m Retractable Pre-Rinse Faucet is used in industrial kitchens, food preparation areas, mass food production facilities, industrial dishwashers, vegetable-fruit washing sinks, and industrial ovens as a pre-rinse spray. Its robust structure and flexible hose make it suitable for heavy use, providing practicality and hygiene during cleaning processes.



10m Hose Reel Capacity



Wall Mount Feature



Adjustable Hose Outlet



Polyamide-Bearing Reel Hub



Stainless Steel Outer Body



10-30 Bar Pressure-Resistant Hose



Technical Specifications

PRODUCT NAME	PRODUCT CODE	DIMENSIONS	WEIGHT
RETRACTABLE PRE-RINSE FAUCET WITH REEL HOSE (10MT)	0902	18x48x47 cm	16 kg

0903

Retractable Pre-Rinse Faucet

with Reel Hose (12mt)

The 12m Retractable Pre-Rinse Faucet is used in industrial kitchens, food preparation areas, mass food production facilities, industrial dishwashers, vegetable-fruit washing sinks, and industrial ovens as a pre-rinse spray. Its robust structure and flexible hose make it suitable for heavy use, providing practicality and hygiene during cleaning processes.



12m Hose Reel Capacity



Wall Mount Feature



Adjustable Hose Outlet



Polyamide-Bearing Reel Hub



Stainless Steel Outer Body



10-30 Bar Pressure-Resistant Hose



Technical Specifications

PRODUCT NAME	PRODUCT CODE	DIMENSIONS	WEIGHT
RETRACTABLE PRE-RINSE FAUCET WITH REEL HOSE (12MT)	0903	18x48x47 cm	16 kg

0904

Retractable Pre-Rinse Faucet

with Reel Hose (15mt)

The 15m Retractable Pre-Rinse Faucet is used in industrial kitchens, food preparation areas, mass food production facilities, industrial dishwashers, vegetable-fruit washing sinks, and industrial ovens as a pre-rinse spray. Its robust structure and flexible hose make it suitable for heavy use, providing practicality and hygiene during cleaning processes.



15m Hose Reel Capacity



Wall Mount Feature



Adjustable Hose Outlet



Polyamide-Bearing Reel Hub



Stainless Steel Outer Body



10-30 Bar Pressure-Resistant Hose



Technical Specifications

PRODUCT NAME	PRODUCT CODE	DIMENSIONS	WEIGHT
RETRACTABLE PRE-RINSE FAUCET WITH REEL HOSE (15MT)	0904	18x48x47 cm	16,5 kg



Washing Equipment Industrial Type Pot Washing Machine







1001

Industrial Type Pot Washing Machine

Industrial Type Pot Washing Machine cleans dirt and grease stuck on pots, pans, and cauldrons in industrial kitchens effortlessly and hands-free using its rotating washing or polishing brush. It can be either permanently mounted to a pot washing sink or used as a mobile unit with its special wheeled cart. The washing brush provides deep cleaning with hot water, while the polishing brush easily removes tarnish and burn marks. Its oil-pressure-driven motor system protects the user from electrical hazards, making it an indispensable hygiene solution in kitchens.



-  High Hygiene Standard
-  Cleaning Brush Feature
-  Polishing Brush Feature
-  Safe Use

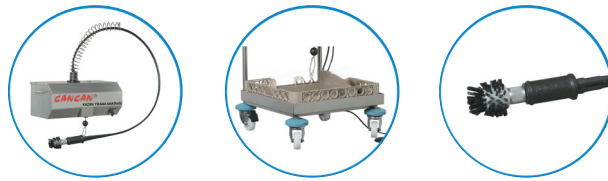

Technical Specifications

PRODUCT NAME	PRODUCT CODE	DIMENSIONS	WEIGHT	TROLLEY WEIGHT
INDUSTRIAL TYPE POT WASHING MACHINE	1001	64x60x125 cm	27 kg	11 kg
POWER	VOLTAGE	FREQUENCY	CURRENT	HYDRAULIC MOTOR SPEED
0,37 kW	220-240 V	50 - 60 HZ	3,3 A	360 RPM
HYDRAULIC MOTOR PRESSUARE	PHASE	TANK	HZ	AMPERE
40 bar	1	2 L	50	1.5

TURKEY CENTER FACTORY

CANCAN MEYVE PRESLERİ SAN. VE . TİC. LTD.ŞTİ.
Modern San. Sit. Yeşiltepe Mah. No: 15/1
ERENLER / SAKARYA / TURKEY

T: +90 (264) 291 49 44
E-Mail: info@cancan.com.tr

RUSSIA CONTACT

E-Mail: dmytro@cancan.com.tr

BELARUS CONTACT

E-Mail: natalia@cancan.com.tr
Phone: +375 29 533 83 99

EUROPE CONTACT

E-Mail: export@cancan.com.tr

MIDDLE EAST CONTACT

E-Mail: sales@cancan.com.tr



Website



Contact Us



cancanmeyvepresleri



cancanmakine



Cancan Meyve
Presleri



@CancanTurkey