

LİMON DİLİMLEME MAKİNESİ

KULLANIM KLAVUZU

LEMON CUTTER

USER GUIDE

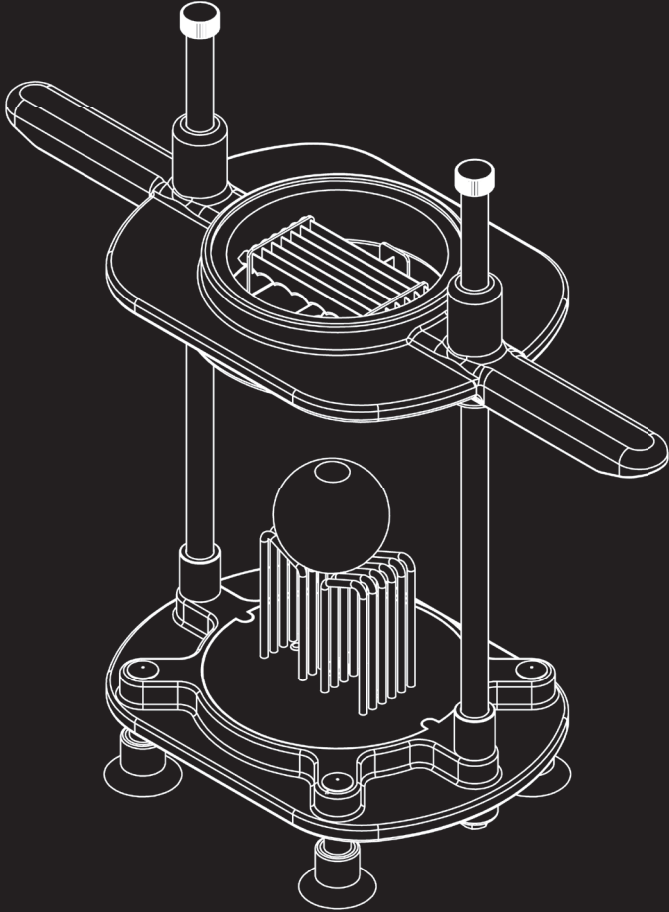

CANCAN®

• SINCE 1958 •

horeca equipment for professional

İÇİNDEKİLER

1 - GİRİŞ	3
2 - GENEL BİLGİLENDİRME	3
3 - TEKNİK ÖZELLİKLER	4
4 - KULLANIM İÇİN TALİMATLAR	
4.1 - Hazırlık	5
4.2 - Çalıştırma	5
4.3 - Temizlik	6
4.4 - Pratik ve Yararlı Bilgiler	8
5 - BAKIM	8
6- YEDEK PARÇA RESİMLERİ VE LİSTESİ.....	9
7 - PROBLEMLER VE ÇÖZÜM YOLLARI	10
8 - CE BELGESİ	11
9- GARANTİ	12

1. GİRİŞ

Cancan Limon Dilimleme Makinesi; Otel, restoran, fast food, catering firmaları vb. mekânlarda ana kullanım alanı Limon olup fazla güç gerektirmeden eşit parçalarda yüksek kalitede kesim sağlar.

2. GENEL BİLGİ

- Öncelikle firmamızı tercih ettiğiniz ve ürünlerimize gösterdiğiniz ilgi ve güven için teşekkür ederiz.
- Ürününüzden en iyi performansı alabilmeniz için lütfen kullanma kılavuzundaki talimatları dikkatlice okuyunuz.
- Ürününüzü kurmadan önce, ürününüzü kullanacak kişilerin kullanma kılavuzundaki bilgileri bildiğinden emin olunuz.
- Kullanma kılavuzunu okumadan önce satın almış olduğunuz ürününüz ile ilgili herhangi bir bakım ve temizlik işlemi yapmayınız.
- Herhangi bir durumda kolayca başvurmak için kullanma kılavuzunuzu ürününüze yakın bir yerde saklayınız.
- Satın almış olduğunuz ürün kolisi içerisinde,
 - 1 Adet Limon Dilimleme Makinesi,
 - 1 Adet Kullanma Kılavuzu Olacaktır.

NOT: Eğer herhangi bir parça hasarlı veya eksikse, tedarikçi firmaya 3 gün içerisinde durumu bildiriniz.

Lütfen ürününüzün kullanımı ile ilgili her türlü sorunuz için bize başvurmaktan çekinmeyiniz. Firmamız ürünlerimiz ile ilgili bütün yorum, öneri ve eleştirilerinize büyük önem vermektedir.

3. TEKNİK ÖZELLİKLER

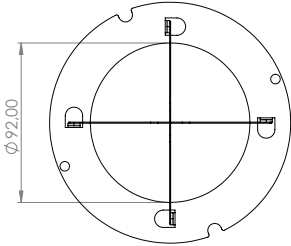
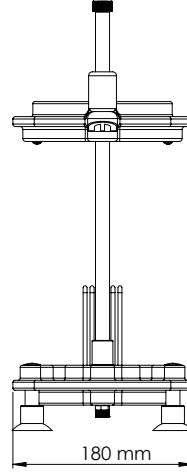
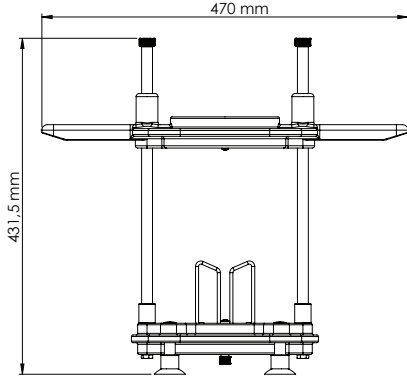

76371 Dilimleme Bıçak (4'li)

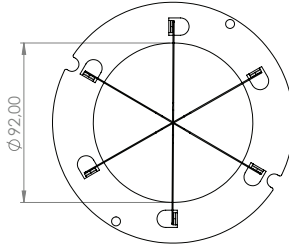

76372 Dilimleme Bıçak (6'li)

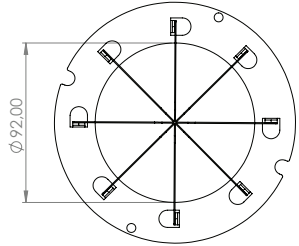

76373 Dilimleme Bıçak 8'li)

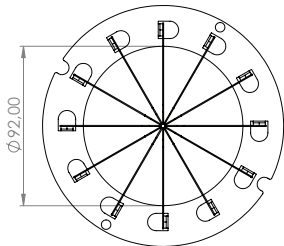

76375 Dilimleme Bıçak (12'li)

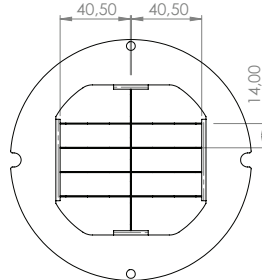

76517 Limon Bıçak (6'li)

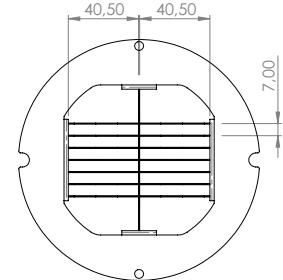

76431 Limon Bıçak (12'li)

NOT: Bıçaklar opsiyoneldir. Makinenin üzerinde talebinize uygun olarak tek bıçaklı gönderim yapılmaktadır. İhtiyaç halinde diğer bıçakları tedarikçi firmadan talep edebilirsiniz.

4. KULLANIM İÇİN TALİMATLAR

4.1 Hazırlık

Ürününüz kullanıma hazır bir şekilde sevk edilir. Ürününüz, ürüne özel kutuya konmuş ve güvence altına alınmıştır. Kutuyu açınız. Keskin bir alet ya da bıçak kullanmanıza gerek yoktur. Ürününüzü kutu içerisinden çıkartınız ve kullanacağınız alana yerleştiriniz.

4.2 Çalıştırma

- Kurulum ve ilk çalıştırma kullanıcı tarafından yapılabilir.
- Ürünü düz ve kaygan olmayan bir zemine yerleştiriniz.
- Ürününüzün özellikle limon ile temas eden bıçak ve itici dilimleyicinin temiz olduğundan emin olun, gerekirse nemli bir bezle siliniz.

Uyarı: Bıçaklar çok keskindir, dikkat ediniz.

- Limonu kesim öncesi mutlaka yıkayınız.
- Limonu tabandaki tellerin üzerine koyunuz.
- İtici kolu çift elle ok yönünde aşağıya doğru bastırınız.

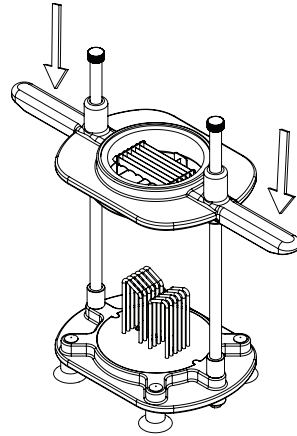
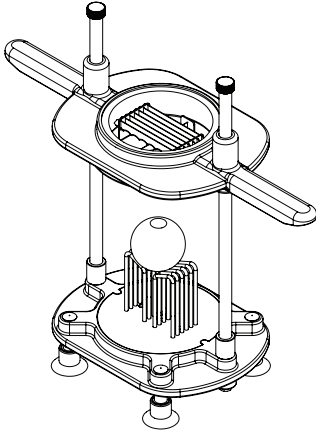

- Dilimleme işleminiz böylece gerçekleşmiş olacaktır. Diğer ürünleriniz için dilimlemeyi aynı adımlarda tekrarlayabilirsiniz.

Uyarı: Bıçaklar çok keskin olduğundan elinizi kesilmelere karşı koruyun.

NOT: Dilimleyici ile bıçak arasındaki mesafeden daha büyük olan limonları kesmeye çalışmayınız. Kesebileceğiniz maksimum limon çapı 8 cm'dir.

4.3 Temizlik

- Ürününüzün ilk kullanımından önce temiz olduğundan emin olunuz.
- İtme bloğunu ve bıçağı her kullanımdan önce iyice yıkayın.
- Ayrıca gün içerisinde kullanırken ihtiyaç durumuna göre iticiyi çıkartıp yıkamak için şekilde görülen Tırtıllı Cıvataları ok yönünde döndürerek **1.Konumdan 2.Konuma** getiriniz.

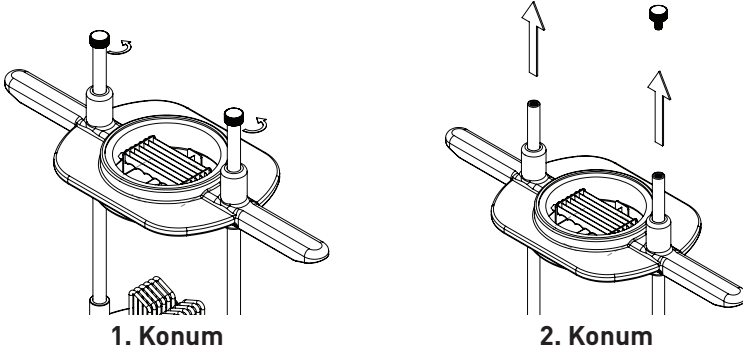

- Bıçağın montajlı olduğu itici kolu ok yönünde yukarı doğru çekerek çıkartınız.

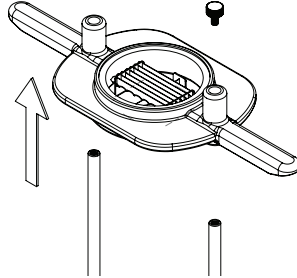

- Bıçağı çıkartmak için öncelikle **1. Konumda** gösterildiği gibi Bıçağın montajlı olduğu itici kolu ters çeviriniz. Yıldız uçlu tornavida yardımı ile vidayı çıkartınız ve **2. Konuma** getiriniz.

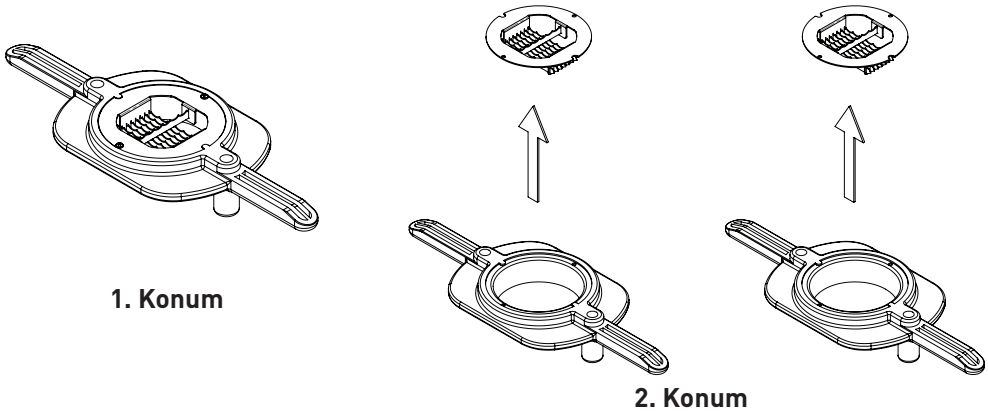

- İtici teli çıkartmak için öncelikle makinenizi ters çevirin ve şekilde gösterilen Tırtıllı Cıvata'yı ok yönünde döndürerek çıkartınız.

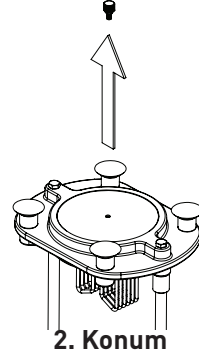
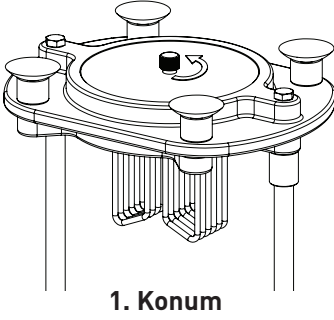

- Şekilde gösterildiği gibi itici sacı ok yönünde çekerek çıkartınız.

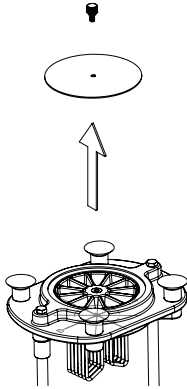

- İtici teli ok yönünde çıkartınız.

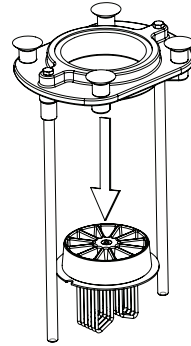

4.4 PRATİK VE YARARLI BİLGİLER

- Kesim esnasında itici kola çift elle bastırmanız kaliteli ve eşit dilimler elde etmenizi sağlar.
- Makinenizin kaydırmaz taban lastikleri ile zemine tutunması için zeminin pürüzsüz ve kuru olmasına dikkat ediniz.

5. BAKIM

- Gerektiğinde, ok ile gösterilen kızak millerini gıdaya uygun silikonlu gres ile yağlayın.

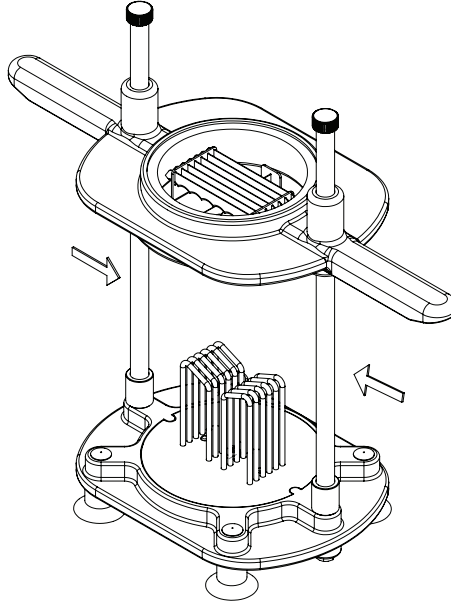

Uyarı: Firmamız, yenileme ve deęiřtirme amaçlı olarak sadece firmamızın yedek parçalarının kullanımını tavsiye etmektedir.

6. YEDEK PARÇA RESİMLERİ VE LİSTESİ

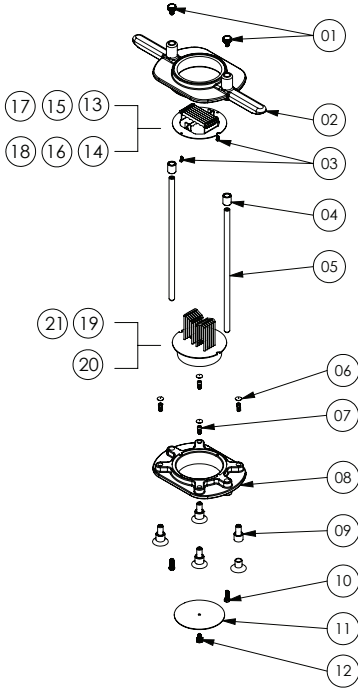

Parça No	Referans No	Parça Adı
1	70786	M8 Tırtıllı Civata
2	44149	MD İtici Kol
3	60304	YSB Vida (Ø4,8x16)(Paslanmaz)
4	72190	Limon Dilimleme Kızak Dayama
5	70731	MD Kızak Mili
6	72139	Imbus M6 Civata Kapağı
7	60031	Imbus M6x16 Civata (Paslanmaz)
8	44148	MD Gövde
9	76551	Vantuz Uzun Ayak (Montajlı)
10	60197	AA M8x25 Civata (Paslanmaz)
11	70819	MD İtici Sac
12	70673	M6x10 Tırtıllı Civata
13	76517	Limon Bıçak (6 Dilim) (Montajlı)
14	76431	Limon Bıçak (12 Dilim) (Montajlı)
15	76371	MD Bıçak (4'lü) (Montajlı)
16	76372	MD Bıçak (6'li) (Montajlı)
17	76373	MD Bıçak (8'li) (Montajlı)
18	76375	MD Bıçak (12'li) (Montajlı)
19	76433	Limon Dilimleme İtici Teli (6-12 Dilim) (Montajlı)
20	76384	MD İtici (4-8)
21	76386	MD İtici (6-12)

7.PROBLEMLER, ÇÖZÜM YOLLARI

Sorun	Muhtemel sebep	Yapılacaklar
Limonu düzgün kesmiyor	Bıçak deforme olmuş olabilir.	Tedarikçi firmayı arayın.
	İtici deforme olmuş olabilir.	Tedarikçi firmayı arayın.
İtici kol zorlanıyor.	Kızak milleri yağsız kalmış olabilir.	Kızak millerini gıdaya uygun silikonlu gres ile yağlayın.
Ürünü düz bir zemine koymama rağmen ürün sallanıyor.	Ayak lastikleri deforme olmuş olabilir.	Tedarikçi firmayı arayın.

LEMON CUTTER

USER GUIDE

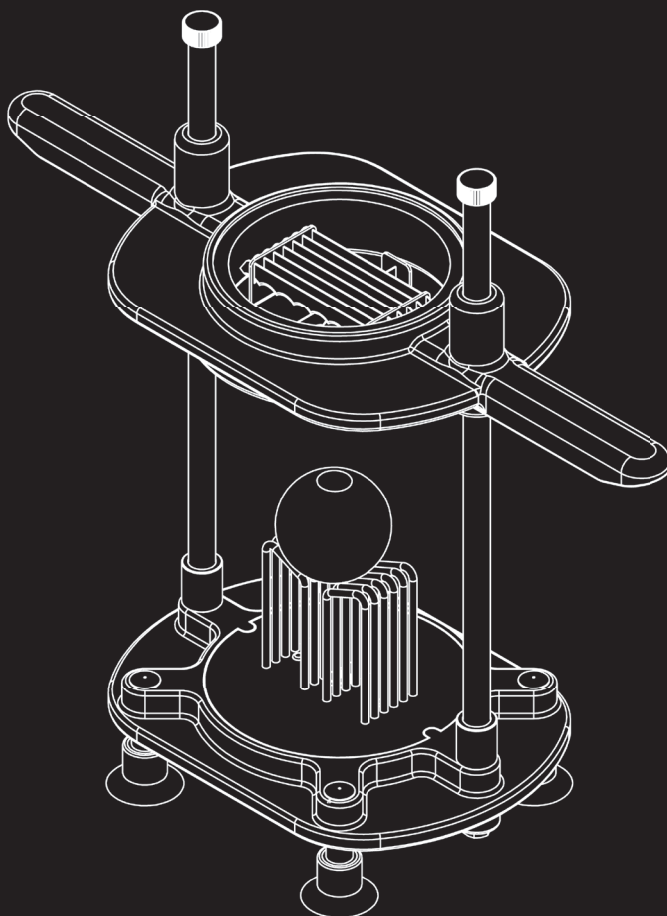

CANCAN®

• SINCE 1958 •

horeca equipment for professional

CONTENTS

1 - INTRODUCTION	16
2 - GENERAL INFORMATION	16
3 - TECHNICAL SPECIFICATIONS	17
4 - INSTRUCTIONS FOR USE	
4.1 - Preparation	18
4.2 - Operation	18
4.3 - Cleaning	19
4.4 - Practical and Useful Information	21
5 - MAINTENANCE	21
6- SPARE PARTS DRAWINGS AND LIST	22
7 - TROUBLE SHOOTING	23
8 - CE CERTIFICATE	24
9- WARRANTY	25

1. INTRODUCTION

The Cancan Lemon Slicer; ensures high quality and equal slices of its primary intended use for lemon in places such as hotels, restaurants, fast food and catering companies etc. without using much force.

2. GENERAL INFORMATION

- First of all, thank you for choosing our company and your interest and trust in our products.
- Please read the instructions in this manual carefully to get the best performance from your product.
- Make sure those who will be using your product know what's included in this manual well before setting up your product.
- Do not clean or perform any maintenance on the product you bought before reading the manual.
- Keep your manual nearby your product to refer to it easily in any situation.
- The product box that you purchased includes;
 - 1 Lemon Slicer,
 - 1 User Manual.

NOTE: If any part is damaged or missing, please notify the supplier of the situation within 3 days.

Please do not hesitate to consult us for any problem regarding the use of your product. Our company greatly cares your comments, suggestions and criticism on our products.

3. TECHNICAL SPECIFICATIONS

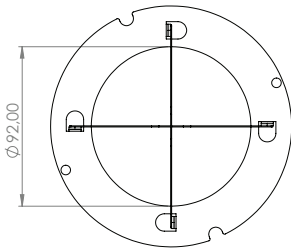
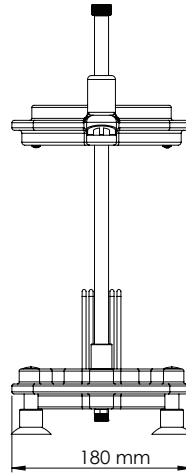
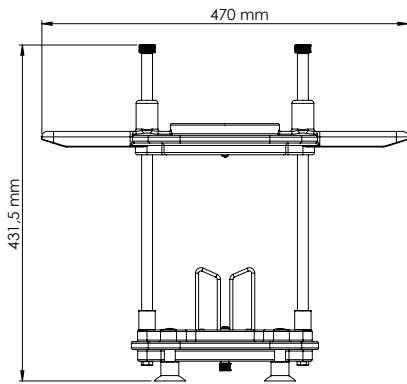

76371 Slicing Blade (4)

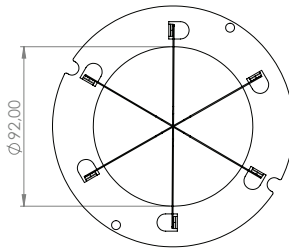

76372 Slicing Blade (6)

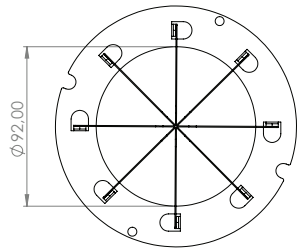

76373 Slicing Blade (8)

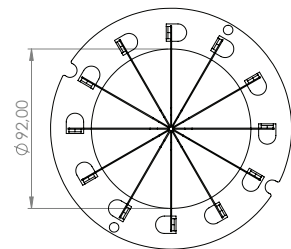

76375 Slicing Blade (12)

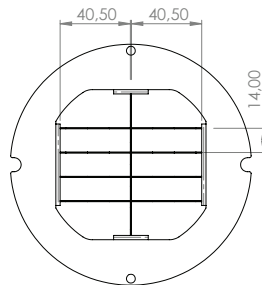

76517 Lemon Blade (6)

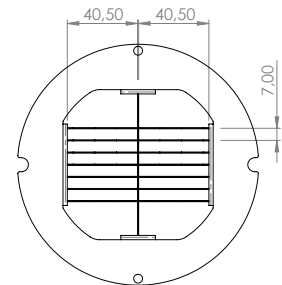

76431 Lemon Blade (12)

NOTE: Blades are optional. Slicer will be sent with a single Blade suiting your request. You may ask for other blades from the supplier as may be required.

4. INSTRUCTIONS FOR USE

4.1 PREPARATION

Your product will be delivered ready for use. Product is put and secured in a box tailored for the product. Open the box. You don't need to use any sharp object or knife. Take your Product out of the box and place it on the area you will use.

4.2 OPERATION

- Setup and first operation can be performed by the user.
- Place the Product on a flat and non-slippery surface.
- Make sure especially the Blade and the Pusher Block of the Product are clean as they will be in contact with the lemon.

Warning: Blades are extremely sharp, be careful.

- Necessarily wash the lemon before cutting.
- Put the lemon on the wires on the deck.
- Press the Pusher Arm downwards in the arrow direction.

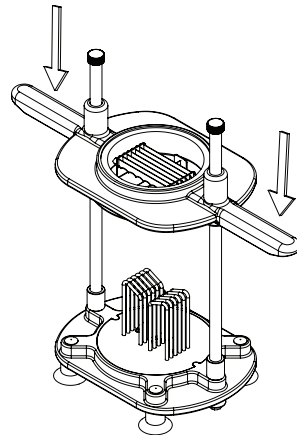
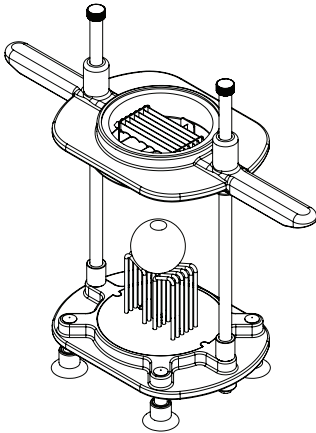

- You can repeat the slicing process performed above with the same steps for your other products.

Warning: Protect your hands against cuts as the blades are extremely sharp.

NOT: Do not try to cut the lemons larger than the distance between the slicer and the blade. Maximum diameter of lemon you can cut in the machine is 8 cm.

4.3 CLEANING

- Make sure your Product is clean before first use.
- Wash the Pusher Block and the Blade thoroughly before each use.
- In addition, in order to remove and wash the Pusher as may be required during the day, turn the Knurled Bolt in the arrow direction and take it from **Position 1** to **Position 2**.

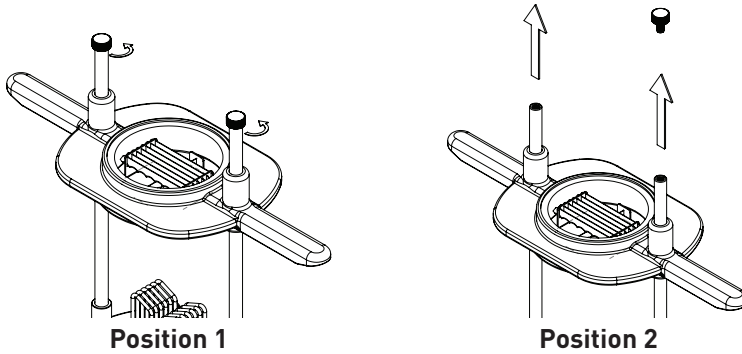

- Pull the Pusher Arm the Blade is assembled in upwards in the arrow direction and remove it.

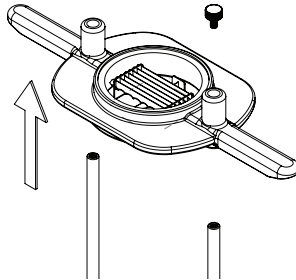

- To remove the Blade first turn the Pusher Arm the Blade is assembled upside down as shown in **Position 1**. Remove the screw with a fillister head screw driver and take it to **Position 2**.

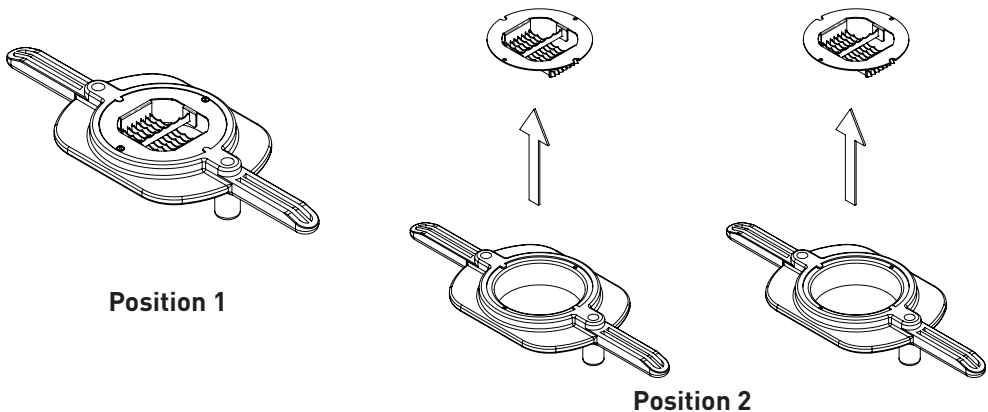

- To remove the Pusher Wire first turn your machine upside down and remove the Knurled Bolt shown in the figure by turning it in the arrow direction.

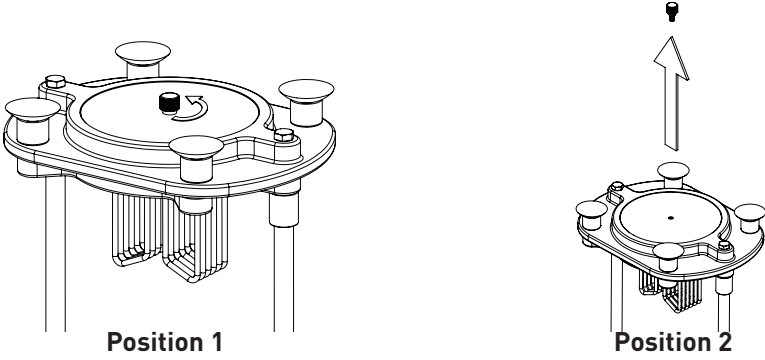

- Pull the Pusher Sheet in the arrow direction as shown in the figure to remove it.

- Remove the Pusher Wire in the arrow direction.

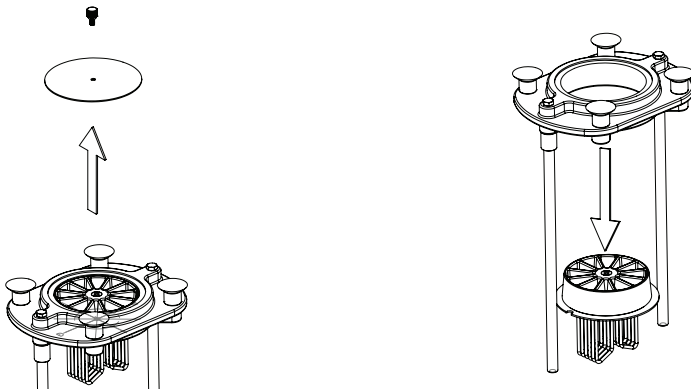

4.4 PRACTICAL AND USEFUL INFORMATION

- During cut, pressing the Pusher Arm with two hands enables you to get quality and equal slices.
- Be careful that the floor the machine will be put on is smooth and dry in order for the machine's non-slip rubber feet hold on to the floor.

5. MAINTENANCE

- When required, lubricate the Slide Shafts shown with arrows with food grade white silicone grease.

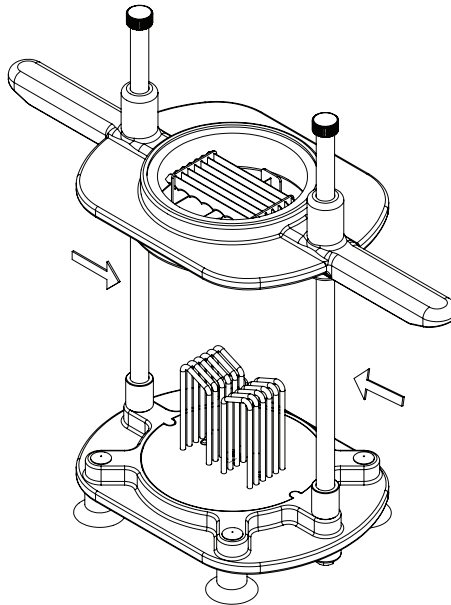

Warning: Our company recommends only the use of our company's spare parts for renewal and replacement purpose.

6. SPARE PARTS DRAWINGS AND LIST

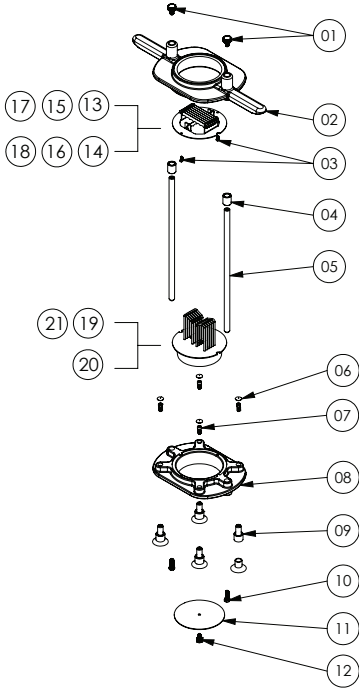

Part No	Reference No	Part Name
1	70786	M8 Knurled Bolt
2	44149	MD Pusher Arm
3	60304	YSB 4,8x16 Screw (Stainless)
4	72190	Lemon Cutter Slide Support Bushing
5	70731	MD Slide Shaft
6	72139	Imbus M6 Bolt Cap
7	60031	Imbus M6x16 Bolt (Stainless)
8	44148	MD Body
9	76551	Suction Cup Long Foot (Assembled)
10	60197	AA M8x25 Bolt (Stainless)
11	70819	MD Pusher Block Sheet
12	70673	M6x16 Knurled Bolt
13	76517	Lemon Cutter Blade (6 Slices)(Assembled)
14	76431	Lemon Cutter Blade (12 Slices)(Assembled)
15	76371	MD Slicer Blade (Four-Slice)(Assembled)
16	76372	MD Slicer Blade (Six-Slice)(Assembled)
17	76373	MD Slicer Blade (Eight-Slice)(Assembled)
18	76375	MD Slicer Blade (Twelve-Slice)(Assembled)
19	76433	Lemon Cutter Pusher Block Wire (6-12 Slices)(Assembled)
20	76384	MD Pusher Block (4-8)(Assembled)
21	76386	MD Pusher Block (6-12)(Assembled)

7. TROUBLE SHOOTING

Problem	Possible Cause	Actions
Lemon not sliced appropriately.	Blade may become deformed.	Call the supplier.
	Pusher Wire may be deformed.	Call the supplier.
Pusher Arm is hard to move.	Slide Shafts may be unlubricated.	Lubricate the Slide Shafts with food grade white silicone grease.
Product shaking even though it's put on a flat surface.	Rubber feet may be deformed.	Call the supplier.

9. WARRANTY

Guarantee Terms:

- 1- All parts of the product are guaranteed by our company.
- 2- Warranty period starts from the delivery date of the product and unless otherwise stated, this period is 2 (two) year.
- 3- If the product malfunctions within the warranty period, the repair time is added to the warranty period. The repair time of the product is maximum 30 (thirty) days. This period shall commence from the date of notification to the seller, dealer, agent, representative or manufacturer.
- 4- If the product is defective due to material or workmanship, or due to erroneous installation, within the warranty period, repairs will be made without labor cost and no fee under the changed part price or any other name.
- 5- The Product: -Within the warranty period from the date of delivery, if the same fault is repeated more than three times in a year or if four or more occurrences of different faults occur, the continuity of the unavailability of the product, -Exceeding maximum time of repairing, - In case the service station is not available, it shall be replaced free of charge in case it is determined that it is impossible to repair the malfunction with a report prepared by one of the seller, dealer, agency, representative, importer or manufacturer.
- 6- In case of occurring problems with guarantee document ,general directorate of consumer and competition protection department of industry and trade ministry is authorized insitituton.

The following conditions are not covered by the warranty:

- 1- Determining that the product has been opened and repaired by unauthorized technical services,
- 2- If the product is damaged due to external influences such as natural disasters, electricity network, telephone line or wrong connection,
- 3- After delivery to the customer, the product is damaged during transportation, dropped or impact and damaged,
- 4- Defects arising from wrong usage of the product in its Instructions Manual,
- 5- Falsification and erasure of the date and serial number on the product document and in the warranty document,
- 6- The warranty is not covered in the event that any object falling within the product or its mechanical parts is blocked by liquid flow or overshooting to prevent air intake.

PRODUCT

Brand : CANCAN
 Model : Lemon Cutter
 Type :
 Delivery Date and Place :
 Seri Number :
 Guarantee time : 2 (two) year
 Maximum Fixing Time : 30 (Thirty) days



AUTHORISED SELLER

Title :
 Address :
 Telephone :
 Invoice Date :
 Invoice No. :
 Stamp / Signature :

Not / Note / Заметки

A series of horizontal dotted lines for writing notes.

LİMON DİLİMLEME MAKİNESİ

KULLANIM KLAVUZU

LEMON CUTTER

USER GUIDE

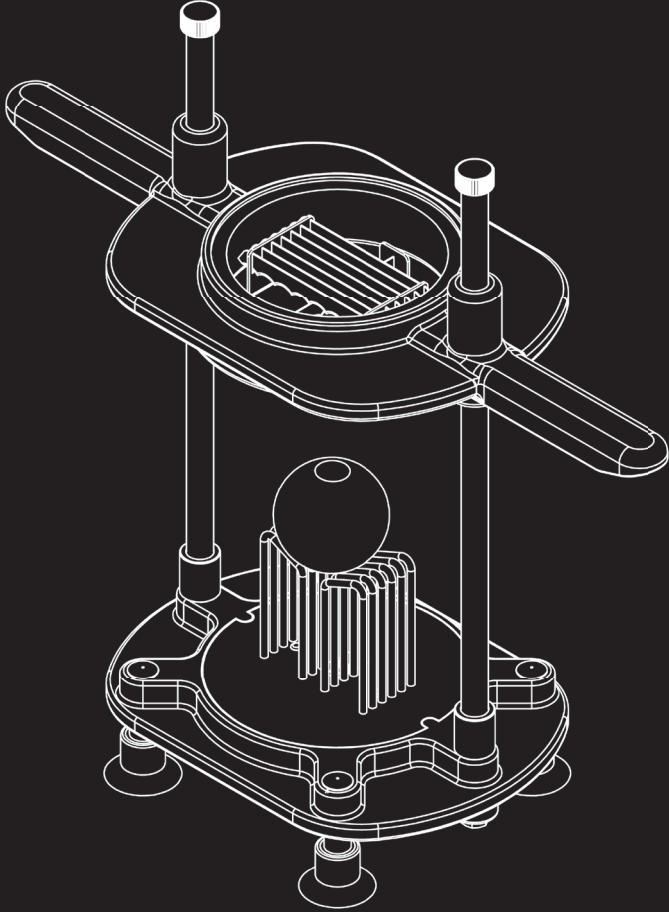

CANCAN®
• SINCE 1958 •

horeca equipment for professional