

**PNÖMATİK PARMAK PATATES  
DİLİMLEME MAKİNESİ**  
KULLANIM KLAVUZU

**PNEUMATIC POTATO CUTTER**  
USER GUIDE

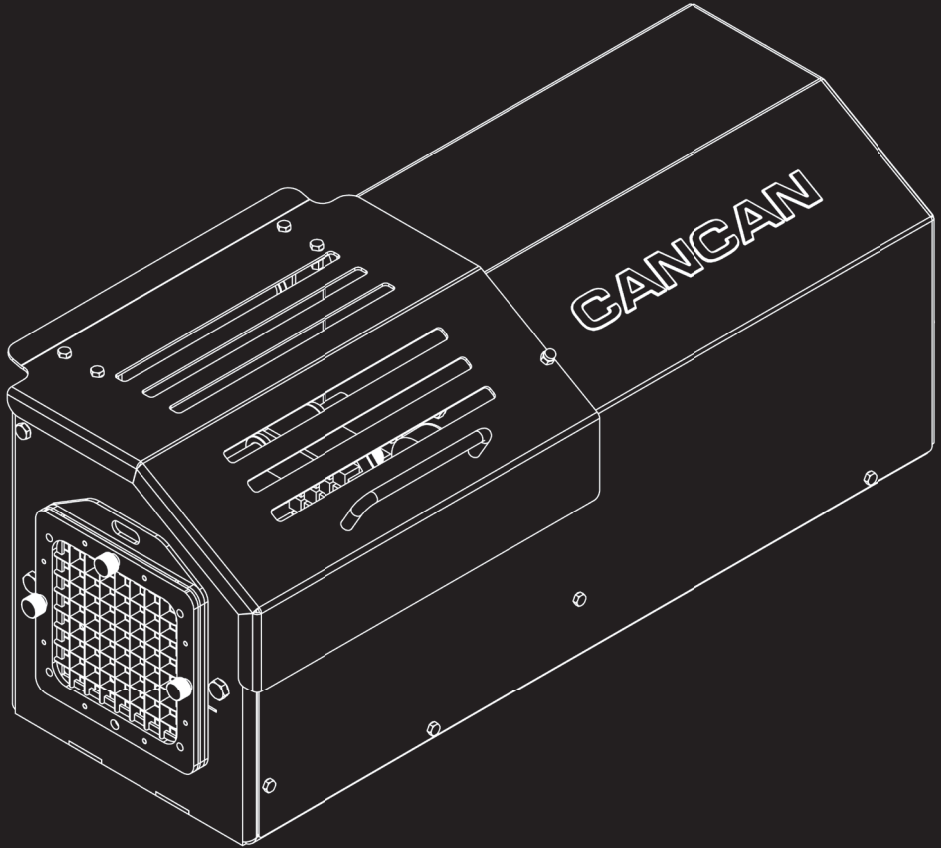

**CANGAN®**

• SINCE 1958 •

horeca equipment for professional

# İÇİNDEKİLER

---

1 - GİRİŞ .....	3
2 - GENEL BİLGİLENDİRME .....	3
3 - TEKNİK ÖZELLİKLER .....	4
4 - KULLANIM İÇİN TALİMATLAR	
4.1 - Hazırlık .....	5
4.2 - Çalıştırma .....	5
4.3 - Temizlik .....	6
4.4 - Pratik ve Yararlı Bilgiler .....	8
5 - BAKIM .....	8
6- YEDEK PARÇA RESİMLERİ ve LİSTESİ .....	9
7 - PROBLEMLER VE ÇÖZÜM YOLLARI .....	10
8 - CE BELGESİ .....	11
9- GARANTİ .....	12

## 1. GİRİŞ

Cancan Pnömatik Parmak Patates Dilimleme Makinesi; Otel, restoran, fast food, catering firmaları vb. mekânlarda ana kullanım alanı patates olmakla beraber salatalık, kabak, patlıcan gibi sebzelerin güç gerektirmeden eşit parçalarda yüksek kalitede kesimini sağlar.

## 2. GENEL BİLGİ

- Öncelikle firmamızı tercih ettiğiniz ve ürünlerimize gösterdiğiniz ilgi ve güven için teşekkür ederiz.
- Ürününüzden en iyi performansı alabilmeniz için lütfen kullanma kılavuzundaki talimatları dikkatlice okuyunuz.
- Ürününüzü kurmadan önce, ürününüzü kullanacak kişilerin kullanma kılavuzundaki bilgileri bildiğinden emin olunuz.
- Kullanma kılavuzunu okumadan önce satın almış olduğunuz ürününüz ile ilgili herhangi bir bakım ve temizlik işlemi yapmayınız.
- Herhangi bir durumda kolayca başvurmak için kullanma kılavuzunuzu ürününüze yakın bir yerde saklayınız.
- Satın almış olduğunuz ürün kolisi içerisinde,
  - 1 Adet Pnömatik Parmak Patates Dilimleme Makinesi,
  - 1 Adet Pnömatik Hava Hortumu (Ø8)(5m)
  - 1 Adet Kullanma Kılavuzu Olacaktır.

**NOT:** Eğer herhangi bir parça hasarlı veya eksikse, tedarikçi firmaya 3 gün içerisinde durumu bildiriniz.

Lütfen ürününüzün kullanımı ile ilgili her türlü sorunuz için bize başvurmaktan çekinmeyiniz. Firmamız ürünlerimiz ile ilgili bütün yorum, öneri ve eleştirilerinize büyük önem vermektedir.

### 3. TEKNİK ÖZELLİKLER

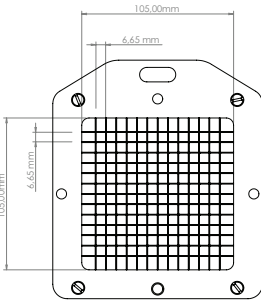
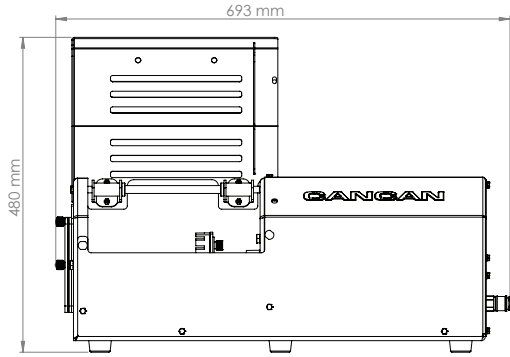
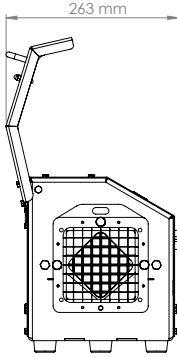
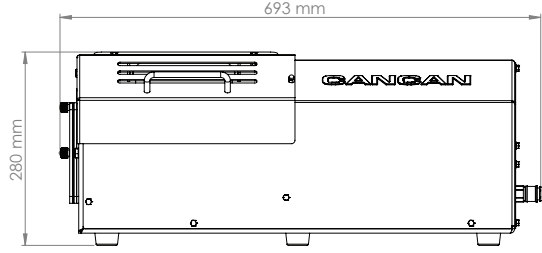
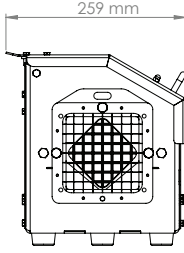

76449 PPD Bıçak (6mm) (Montajlı)

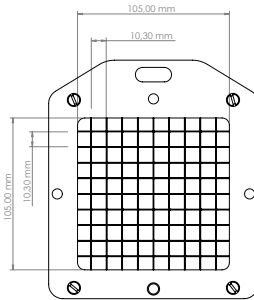

76448 PPD Bıçak (10mm) (Montajlı)

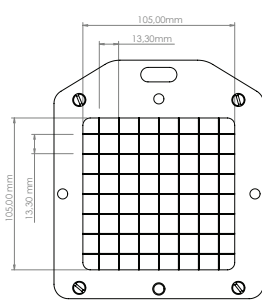

76447 PPD Bıçak (13mm) (Montajlı)

**NOT: Bıçaklar opsiyoneldir. Makinenin üzerinde talebinize uygun olarak tek bıçaklı gönderim yapılmaktadır. İhtiyaç halinde diğer bıçakları tedarikçi firmadan talep edebilirsiniz.**

## 4. KULLANIM İÇİN TALİMATLAR

### 4.1 Hazırlık

Ürününüz kullanıma hazır bir şekilde sevk edilir. Ürününüz, ürüne özel kutuya konmuş ve güvence altına alınmıştır. Kutuyu açınız. Keskin bir alet ya da bıçak kullanmanıza gerek yoktur. Ürününüzü kutu içerisinden çıkartınız ve kullanacağınız alana yerleştiriniz.

- Hava kompresörünü üretici yönergelerine göre kurun (kompresör ünite ile beraber verilmaz). Minimum basınç 6 Bar – motor gücü 1,5HP ve 2HP arasında olan ürün kullanılması önerilir. (1adet patates kesmek için tüketilen hava miktarı 10 Lt'dir.)
- Makinenin hava yakını kompresörün çıkışına bağlayınız.

### 4.2 Çalıştırma

- Kurulum ve ilk çalıştırma kullanıcı tarafından yapılabilir.
- Ürünü düz ve kaygan olmayan bir zemine yerleştiriniz.
- Ürünü yatay bir şekilde monte ediniz.
- Ürünün özellikle patates ile temas eden bıçak ve itici kısmının temiz olduğundan emin olun, gerekirse nemli bir bez ile siliniz.

**Uyarı: Bu ünite yalnızca bir (1) Kişi tarafından çalıştırılmak üzere tasarlanmıştır.**

- Patatesi kesim öncesi mutlaka yıkayınız.
- Ürünün kapağını açın ve dilimleyeceğiniz patatesi itici ile bıçak arasına dikkatlice koyunuz.

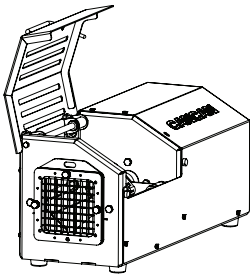
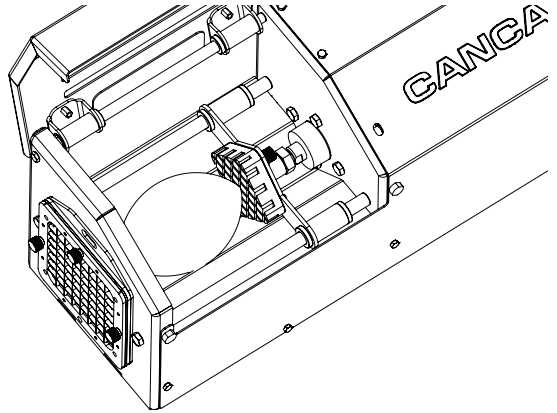
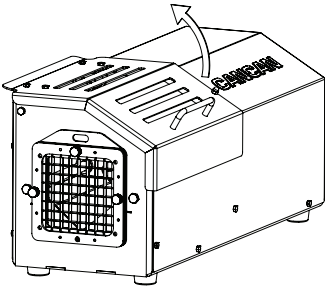

- Kapağı tamamen kapalı konuma getiriniz ve böylece dilimleme işlemi başlamış olacaktır.

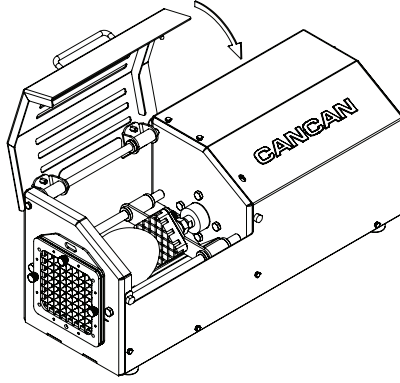

**Uyarı: Bıçaklar çok keskin olduğundan elinizi kesilmelere karşı koruyun.**

**Uyarı: Kesilen patateslerin etrafa dağılmaması için bıçakların önüne uygun bir gastronomik küvet koyunuz.**

**Not: Ünite ilk kullanıldığında düzgün çalışmazsa CANCAN müşteri hizmetlerini arayınız.**

### 4.3 Temizlik

- Ürünün ilk kullanımından önce temiz olduğundan emin olunuz.
- Bıçak Temizliği;

Tırtıllı Somunları saat yönü tersine olacak şekilde ok yönünde çevirerek gevşetiniz **(Konum 1)**

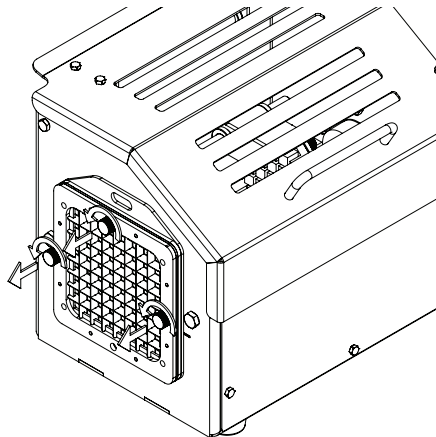

**Konum 1**

- Bıçağı ok yönünde dikkatlice **Konum 2**'den **Konum 3** 'e getiriniz.

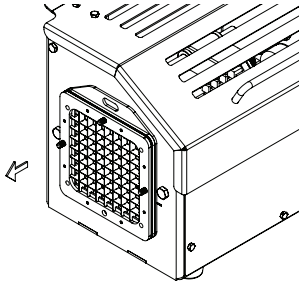

Konum 2

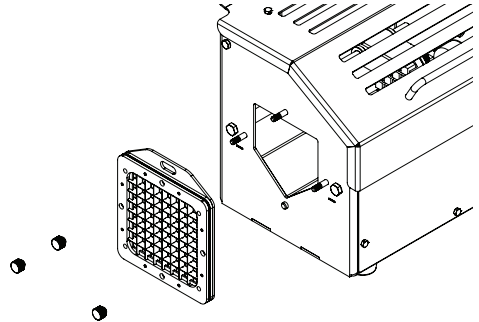

Konum 3

- İtici Temizliği;  
Kapağı ok yönünde **Konum 1**'den **Konum 2**'e getiriniz.

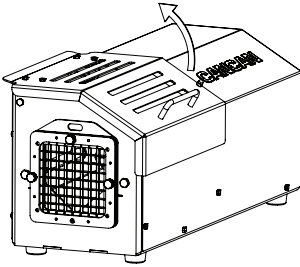

Konum 1

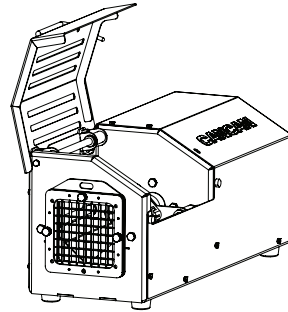

Konum 2

- Tırtıllı civatayı saat yönü tersine ok yönünde çeviriniz ve İticiyi ok yönünde çekerek **Konum 4**'ten **Konum 5**'e getiriniz.

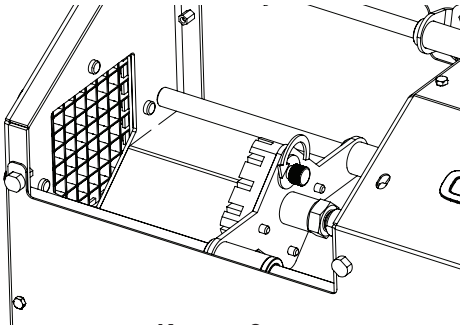

Konum 3

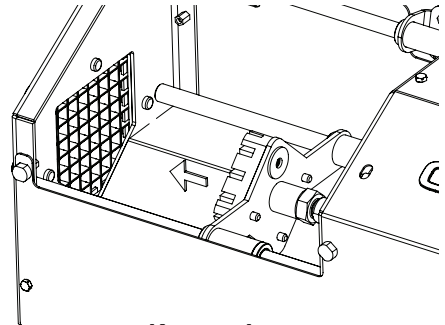

Konum 4

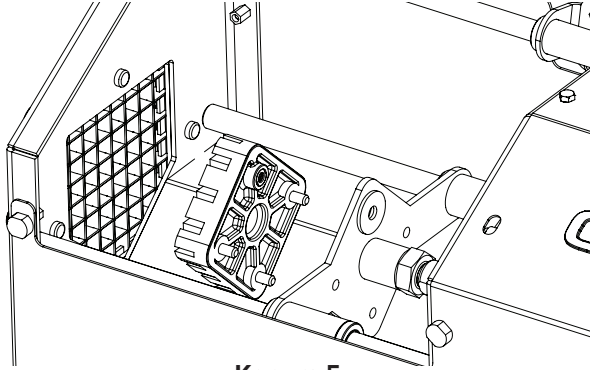
**Konum 5**

- Ürünün gövdesini nemli bir bez yardımı ile temizleyebilirsiniz.
- İticiyi ılık suda yıkayabilirsiniz. **(Bulaşık makinesinde kesinlikle yıkamayınız.)**
- Bıçağın tamamı paslanmaz olduğu için bulaşık makinesinde yıkayabilirsiniz.

#### 4.4 PRATİK VE YARARLI BİLGİLER

- Kesim esnasında kapağı tam açmanız, sebzeği hazneye düzgünce yerleştirmeniz kesim kalitenizi arttırır.
- Makineniz kaydırmaz taban lastikleri ile zemine tutunduğundan zeminin pürüzsüz ve kuru olmasına dikkat ediniz.

#### 5. BAKIM

- Gerekteğinde, kızak millerini gıdaya uygun beyaz silikonlu gres ile yağlayın.

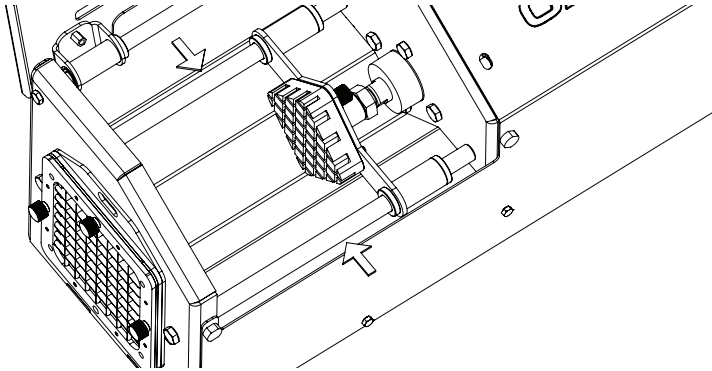

**Uyarı: Firmamız, yenileme ve deęiřtirme amaçlı olarak sadece firmamızın yedek parçalarının kullanımını tavsiye etmektedir.**

## 6. YEDEK PARÇA RESİMLERİ VE LİSTESİ

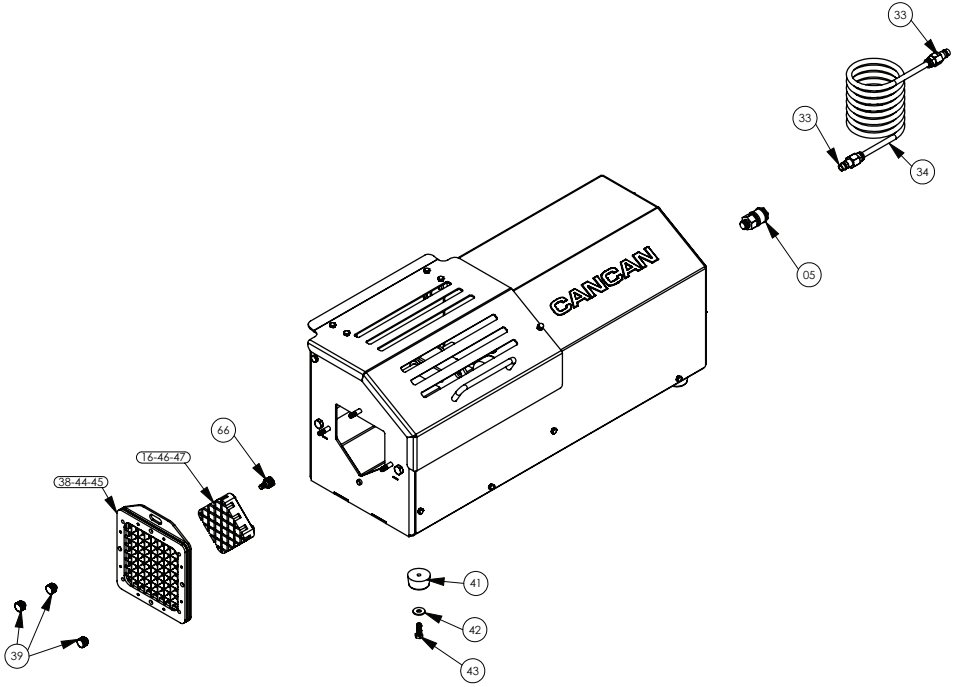

Parça No	Referans No	Parça Adı
05	60361	Hava Jakı
16	76451	MPD İtici (13mm) (Montajlı)
33	60362	Hava Jakı Erkek
34	60363	Pnömatik Hava Hortumu (Ø8) (5m)
38	76447	PPD Bıçak (13mm) (Montajlı)
39	77159	M6 Tırtıllı Somun
41	44062	PVC Tampon
42	60230	M6 Geniş Pul (Paslanmaz)
43	60006	AA M6x20 Civata (Paslanmaz)
44	76448	PPD Bıçak (10mm) (Montajlı)
45	76449	PPD Bıçak (6mm) (Montajlı)
46	76452	MPD İtici (10mm) (Montajlı)
47	76453	MPD İtici (6mm) (Montajlı)
66	70673	M6 Tırtıllı Civata

**7.PROBLEMLER, ÇÖZÜM YOLLARI**

<b>Sorun</b>	<b>Muhtemel sebep</b>	<b>Yapılacaklar</b>
<b>Patatesi düzgün kesmiyor</b>	Bıçak deforme olmuş olabilir.	Tedarikçi firmayı arayın.
	İtici deforme olmuş olabilir.	Tedarikçi firmayı arayın.
<b>Kapak kapandığında kesim gerçekleşmiyor.</b>	Switch arızalı olabilir.	Tedarikçi firmayı arayın.
<b>Ürünü düz bir zemine koymama rağmen sallanıyor.</b>	Ayak lastikleri deforme olmuş olabilir.	Tedarikçi firmayı arayın.

## 8. CE BELGESİ

**CANCAN®**  
• SINCE 1958 •



AT UYGUNLUK BEYANI  
İMALATÇI ADI - ADRESİ

EC DECLARATION OF CONFORMITY  
MANUFACTURER NAME - ADDRESS

**CANCAN MEYVE PRESLERİ SAN. VE TİC. LTD. ŞTİ.**

Modern Sanayi Sitesi 8030 SOK. No:15 ERENLER  
Adapazarı – Sakarya , TURKEY

Aşağıda tanımlanmış olan ekipmanlar için **Makina Yönetmeliği 2006 / 42 / AT** nin uygulanabilen gerekliliklerinin yerine getirildiğini ve sorumluluğun alınmış olduğunu beyan ederiz.

**Makina**

The undersigned declares that the described products meet the essential requirements of the below mentioned standards as based on **Machinery Directive 2006 / 42 / EC**.

Aşağıda tanımlanan ürünler iç üretim kontrollerine bağlı olarak **Firmamız** tarafından kontrol edilmiştir.

The item of equipment identified below has been subject to internal manufacturing checks with monitoring of the final assessment by **our company**.

ÜRÜN TANIMI :

EQUIPMENT DESCRIPTION :

PNÖMATİK PARMAK PATATES DİLİMLEME MAKİNESİ

PNEUMATIC FINGER POTATO SLICING MACHINE

MODEL/ TİP/ SERİ NO :

MODEL/ TYPE/ SERIAL NU. :

1305-1 PNÖMATİK PARMAK PATATES DİLİMLEME MAKİNESİ (6 mm)  
1305-2 PNÖMATİK PARMAK PATATES DİLİMLEME MAKİNESİ (7 mm)  
1305-3 PNÖMATİK PARMAK PATATES DİLİMLEME MAKİNESİ (13 mm)

1305-1 PNEUMATIC FINGER POTATO SLICING MACHINE (6 mm)  
1305-2 PNEUMATIC FINGER POTATO SLICING MACHINE (10 mm)  
1305-3 PNEUMATIC FINGER POTATO SLICING MACHINE (13 mm)

YÖNETMELİKLER:

Makina Emniyeti Yönetmeliği 2006 / 42 / AT

DIRECTIVES:

Machinery Safety Directive 2006 / 42 / EC

UYGULANAN UYUMLAŞTIRILMIŞ STANDARTLAR:

Regulations Applied acc. to HARMONIZE STANDARDS:

EN ISO 12100:2010, EN 1672-2:2020

TEKNİK DOSYAYI HAZIRLAMAKLA YETKİLİ OLAN KİŞİ ADI VE ADRESİ -  
NAME AND ADDRESS OF THE PERSON AUTHORISED TO COMPILE THE TECHNICAL FILE.:

AD\_SOYAD / NAME\_SURNAME  
ADRESİ- ADDRESS

: Harun GÜLÇELER  
: Modern Sanayi Sitesi 8030 SOK. No:15 ERENLER  
Adapazarı – Sakarya, TURKEY

İMALATÇI ADINA - SIGNED ON BEHALF OF THE MANUFACTURER

AD\_SOYAD- NAME\_SURNAME  
GÖREV - POSITION  
YER /TARİH – PLACE / DATE  
İMZA – SIGNATURE

: TUNÇ ÖZÜÜĞÜRLÜ  
: Genel Müdür – General Manager  
: SAKARYA / 10.05.2023  
:

**CANCAN®**  
MEYVE PRESLERİ SAN. VE TİC. LTD. ŞTİ.  
Yıldırım Mh. 8030 Sok. No:15 Erenler / SAKARYA  
Tic. Sic. No: 190929  
Mersis No: 810 00378000006 Tic. Sic. No: 15230





# PNEUMATIC POTATO CUTTER

## USER GUIDE

---

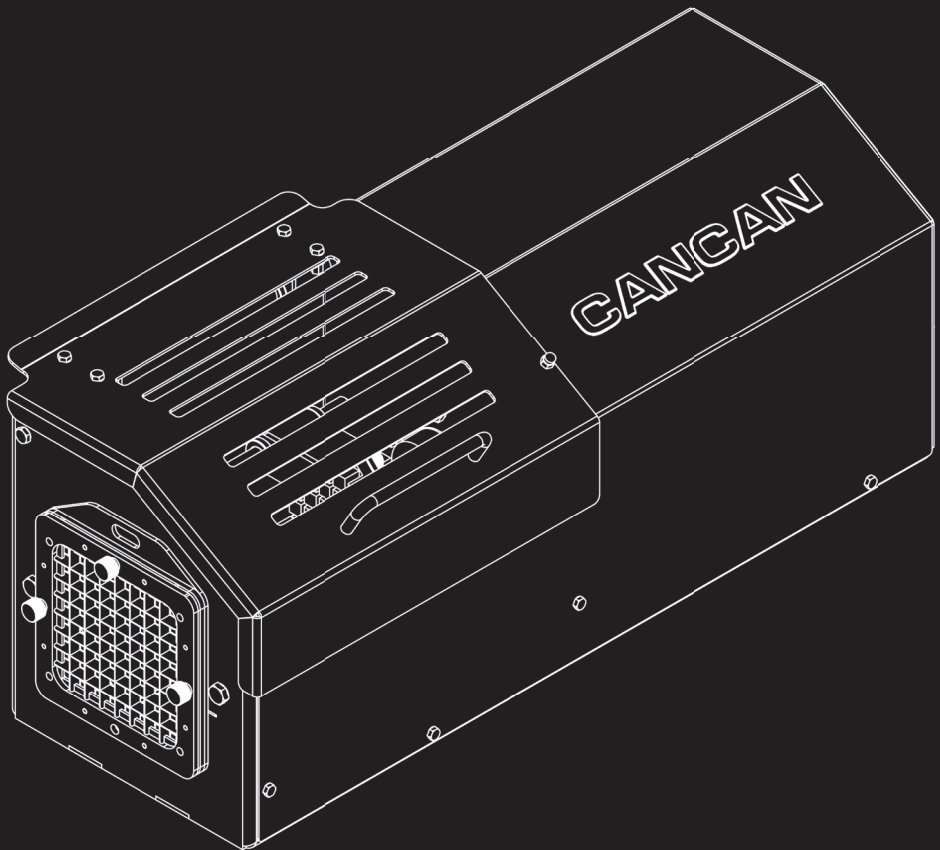

**CANCAN**<sup>®</sup>

• SINCE 1958 •

horeca equipment for professional

# CONTENTS

---

1 - INTRODUCTION .....	16
2 - GENERAL INFORMATION .....	16
3 - TECHNICAL SPECIFICATIONS .....	17
4 - INSTRUCTIONS FOR USE	
4.1 - Preparation .....	18
4.2 - Operation .....	18
4.3 - Cleaning .....	19
4.4 - Practical and Useful Information .....	21
5 - MAINTENANCE .....	21
6- SPARE PARTS DRAWINGS AND LIST .....	22
7 - TROUBLE SHOOTING .....	23
8 - CE CERTIFICATE .....	24
9- WARRANTY .....	25

## 1. INTRODUCTION

The Cancan Pneumatic Potato cutter; ensures high quality and equal slices of vegetables like cucumber, zucchini, aubergine and its primary intended use of potato in places such as hotels, restaurants, fast food and catering companies etc. without using any force.

## 2. GENERAL INFORMATION

- First of all, thank you for choosing our company and your interest and trust in our products.
- Please read the instructions in this manual carefully to get the best performance from your product.
- Make sure those who will be using your product know what's included in this manual well before setting up your product.
- Do not clean or perform any maintenance on the product you bought before reading the manual.
- Keep your manual nearby your product to refer to it easily in any situation.
- The product box that you purchased includes;
  - 1 Pneumatic Potato Cutter,
  - 1 Pneumatic Air Hose (Ø8)(5m)
  - 1 User Manual.

**NOTE:** If any part is damaged or missing, please notify the supplier of the situation within 3 days.

Please do not hesitate to consult us for any problem regarding the use of your product. Our company greatly cares your comments, suggestions and criticism on our products.

### 3. TECHNICAL SPECIFICATIONS

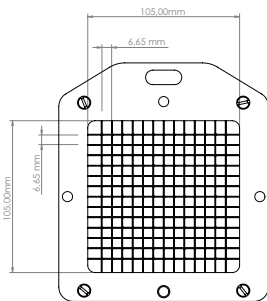
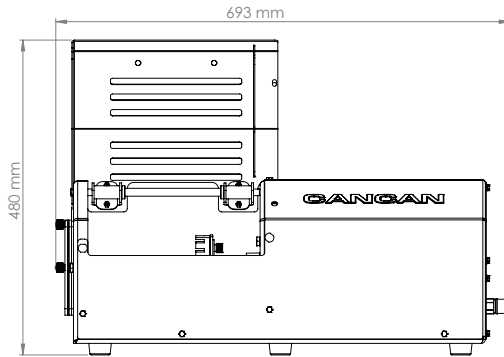
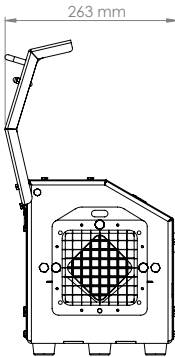
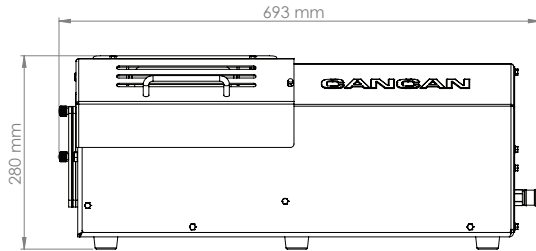
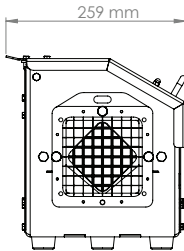

76449 PPD Blade (6mm) (Mounted)

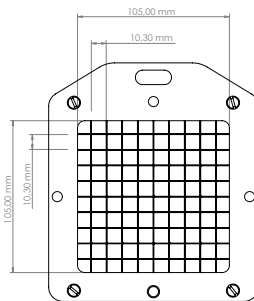

76448 PPD Blade (10mm) (Mounted)

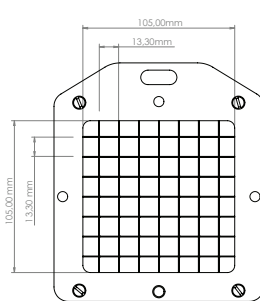

76447 PPD Blade (13mm) (Mounted)

**NOTE: Blades are optional. Slicer will be sent with a single blade suiting your request. You may ask for other blades from the supplier as may be required.**

## 4. INSTRUCTIONS FOR USE

### 4.1 PREPARATION

Your product will be delivered ready for use. Product is put and secured in a box tailored for the product. Open the box. You don't need to use any sharp object or knife. Take your product out of the box and place it on the area you will use.

- Set up the air compressor according to the manufacturer's instructions (not delivered with the unit). It is suggested to use a Compressor with a minimum pressure of 6 Bars - an engine power of between 1,5HP and 2HP. (Air consumed to slice a potato is 10 Lt).
- Connect the air jack of the Cutter to the Compressor outlet.

### 4.2 OPERATION

- Setup and first operation can be performed by the user.
- Place the product on a flat and non-slippery surface.
- Mount the product horizontally.
- Make sure especially the Blade and the Pusher Block of the product are clean as they will be in contact with the potato. Wipe them with a moist cloth if necessary.

**Note: This unit is designed to be operated by a single person.**

- Necessarily wash the potato before slicing.
- Open the lid of the product and carefully place the potato you will slice between the Pusher Block and the Blade.

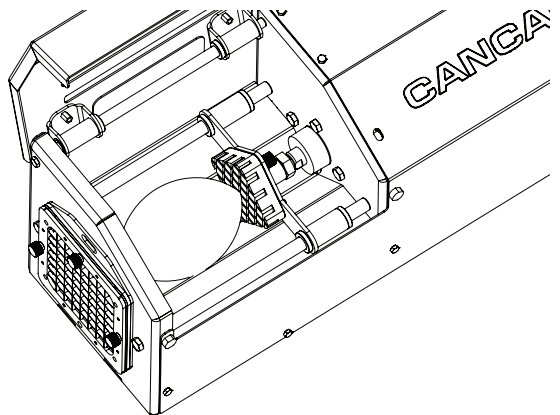
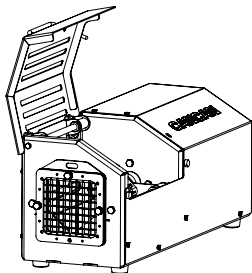
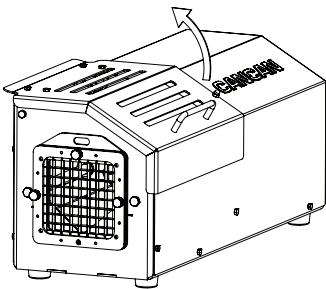

- Fully close the lid in order to start the slicing process.

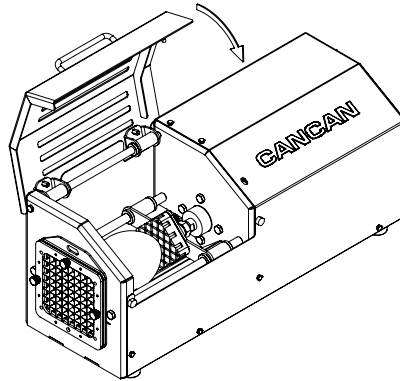

**Warning: Protect your hands against cuts as the blades are extremely sharp.**

**Warning: Place a suitable gastronomy tub in front of the blades to prevent sliced potatoes scatter around.**

**Note: If the unit does not work properly in first use call CANCAN Customer Service.**

### 4.3 CLEANING

- Make sure the product is clean before first use.
- Blade Cleaning;

Turn the Knurled Nuts counter-clockwise in the arrow direction to loosen them **(Position 1)**

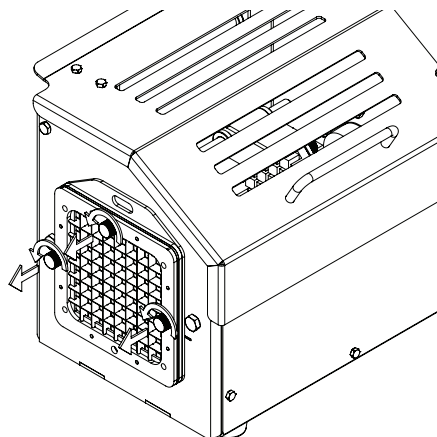

**Position 1**

- Carefully take the Blade from **Position 2** to **Position 3**.

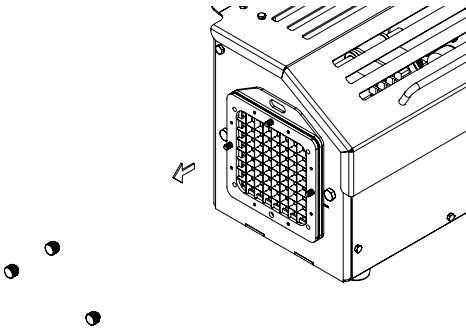

**Position 2**

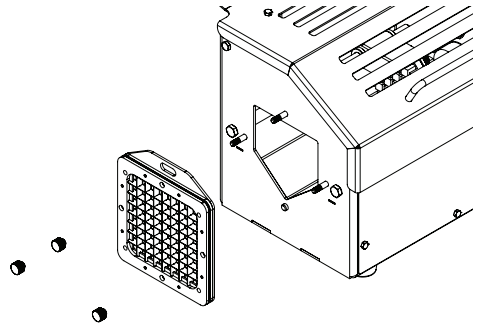

**Position 3**

- Pusher Block Cleaning;  
Take the lid from **Position 1** to **Position 2** in the arrow direction.

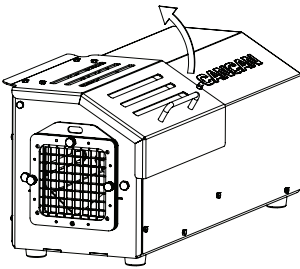

**Position 1**

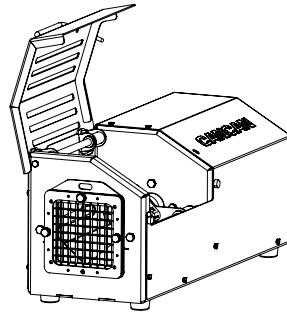

**Position 2**

- Turn the knurled Nut in the arrow direction counter-clockwise and take the Pusher Block from **Position 4** to **Position 5**.

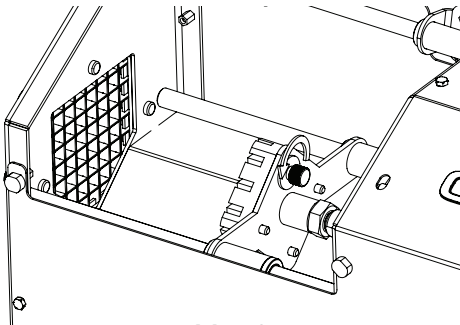

**Position 3**

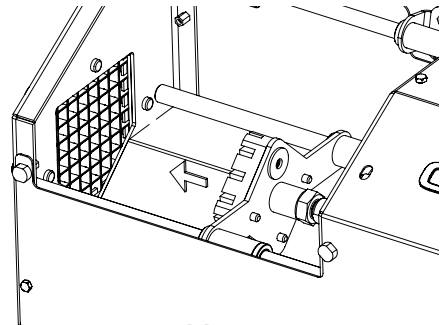

**Position 4**

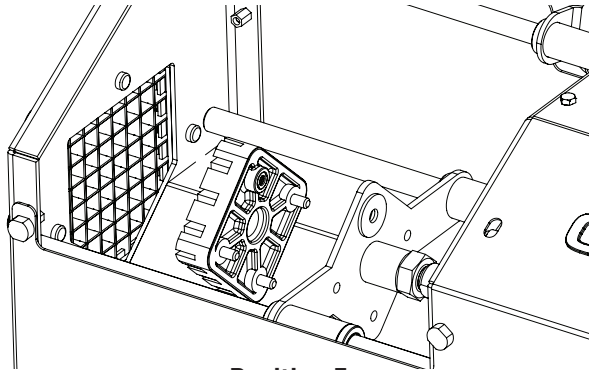

**Position 5**

- You can clean the product Body with a moist cloth.
- You can wash the Pusher Block with warm water. **(Do not wash in the dishwasher.)**
- The Blade is all stainless, you can wash it in the dishwasher.

#### **4.4 PRACTICAL AND USEFUL INFORMATION**

- Opening the cover fully while cutting and placing the vegetables centered in the chamber will increase your cutting quality.
- Since your machine is attached to the floor with non-slip rubbers, make sure that the floor is smooth and dry.

#### **5. MAINTENANCE**

- When required, lubricate the guide shafts with food grade white silicone grease.

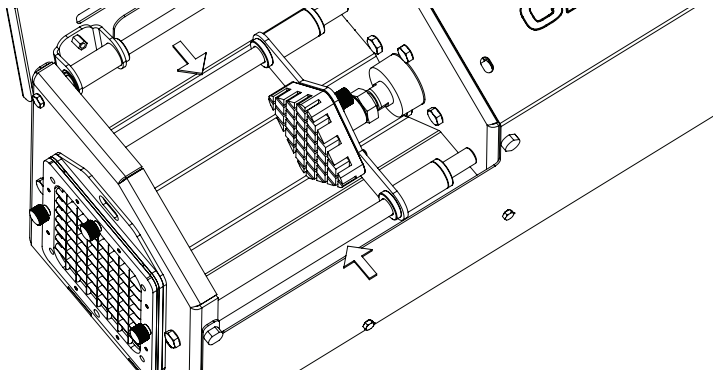

**Warning: Our company recommends only the use of our company's spare parts for renewal and replacement purpose.**

## 6. SPARE PARTS DRAWINGS AND LIST

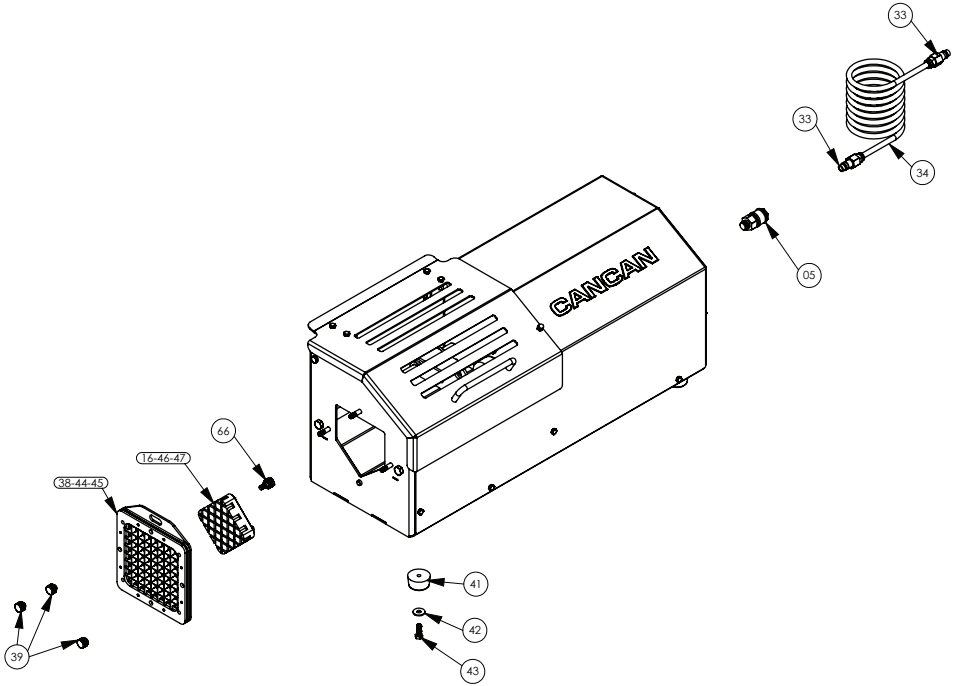

Part No	Referance No	Part Name
05	60361	Air Jack
16	76451	MPD Pusher Block (13mm)[Assembled]
33	60362	Air Jack Male
34	60363	Pneumatic Air Hose (Ø8)(5m)
38	76447	PPD Blade (13mm)[Assembled]
39	77159	M6 Knurled Nut
41	44062	PVC Tampon
42	60230	MP Wide Washer (Stainless)
43	60006	AA M6x20 Bolt (Stainless)
44	76448	PPD Blade (10mm)[Assembled]
45	76449	PPD Blade (6mm)[Assembled]
46	76452	MPD Pusher Block (10mm)[Assembled]
47	76453	MPD Pusher Block (6mm)[Assembled]
66	70673	M6 Knurled Bolt

## 7. TROUBLE SHOOTING

<b>Problem</b>	<b>Possible Cause</b>	<b>Actions</b>
<b>Potato not sliced properly</b>	Blade may become deformed.	Call the supplier.
	Pusher Block may become deformed.	Call the supplier.
<b>Cutting not started when the lid is closed.</b>	Switch may be out of order.	Call the supplier.
<b>Product shaking even though it's put on a flat surface.</b>	Foot rubbers may become deformed.	Call the supplier.



## 9. WARRANTY

### Guarantee Terms:

- 1- All parts of the product are guaranteed by our company.
- 2- Warranty period starts from the delivery date of the product and unless otherwise stated, this period is 2 (two) year.
- 3- If the product malfunctions within the warranty period, the repair time is added to the warranty period. The repair time of the product is maximum 30 (thirty) days. This period shall commence from the date of notification to the seller, dealer, agent, representative or manufacturer.
- 4- If the product is defective due to material or workmanship, or due to erroneous installation, within the warranty period, repairs will be made without labor cost and no fee under the changed part price or any other name.
- 5- The Product: -Within the warranty period from the date of delivery, if the same fault is repeated more than three times in a year or if four or more occurrences of different faults occur, the continuity of the unavailability of the product, -Exceeding maximum time of repairing, - In case the service station is not available, it shall be replaced free of charge in case it is determined that it is impossible to repair the malfunction with a report prepared by one of the seller, dealer, agency, representative, importer or manufacturer.
- 6- In case of occurring problems with guarantee document ,general directorate of consumer and competition protection department of industry and trade ministry is authorized insititution.

### The following conditions are not covered by the warranty:

- 1- Determining that the product has been opened and repaired by unauthorized technical services,
- 2- If the product is damaged due to external influences such as natural disasters, electricity network, telephone line or wrong connection,
- 3- After delivery to the customer, the product is damaged during transportation, dropped or impact and damaged,
- 4- Defects arising from wrong usage of the product in its Instructions Manual,
- 5- Falsification and erasure of the date and serial number on the product document and in the warranty document,
- 6- The warranty is not covered in the event that any object falling within the product or its mechanical parts is blocked by liquid flow or overshooting to prevent air intake.

### PRODUCT

Brand : CANCAN  
 Model : Pneumatic Potato Cutter  
 Type :  
 Delivery Date and Place :  
 Seri Number :  
 Guarantee time : 2 (two) year  
 Maximum Fixing Time : 30 (Thirty) days



### AUTHORISED SELLER

Title :  
 Address :  
 Telephone :  
 Invoice Date :  
 Invoice No. :  
 Stamp / Signature :

### Not / Note / Заметки

A series of horizontal dotted lines for writing notes.



# PNÖMATİK PARMAK PATATES DİLİMLEME MAKİNESİ KULLANIM KLAVUZU

## PNEUMATIC POTATO CUTTER USER GUIDE

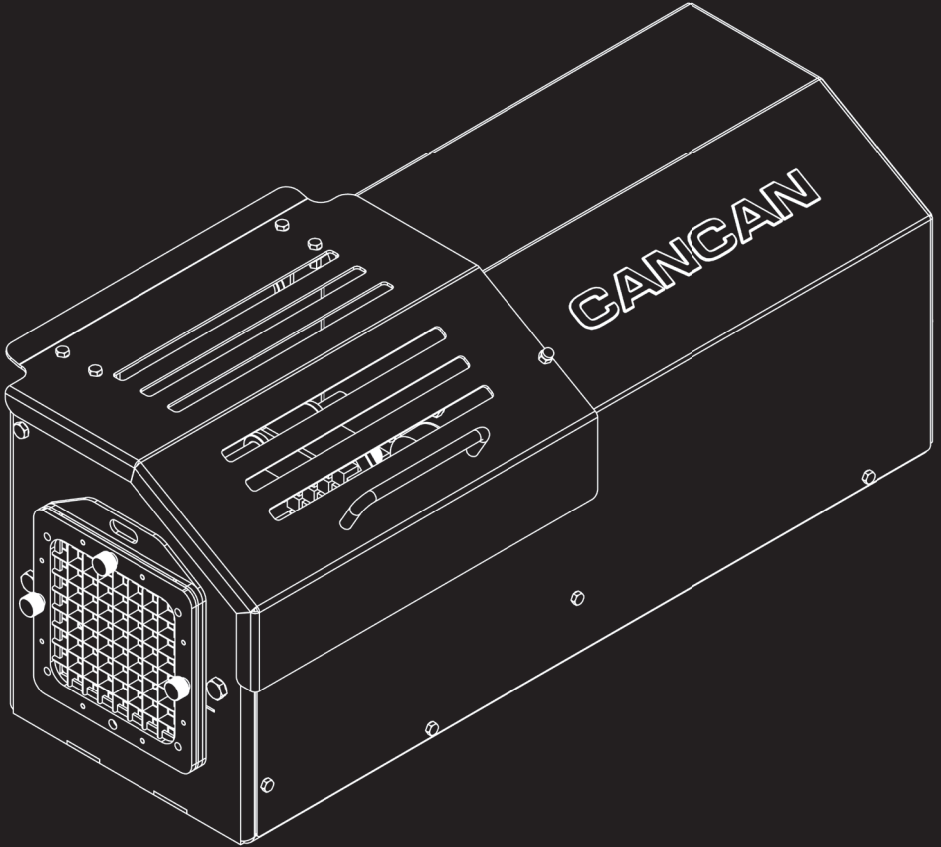

**CANGCAN®**  
• SINCE 1958 •

horeca equipment for professional