

# CANCAN®

• SINCE 1958 •

## WASHING EQUIPMENTS

Horeca Equipment For Professionals

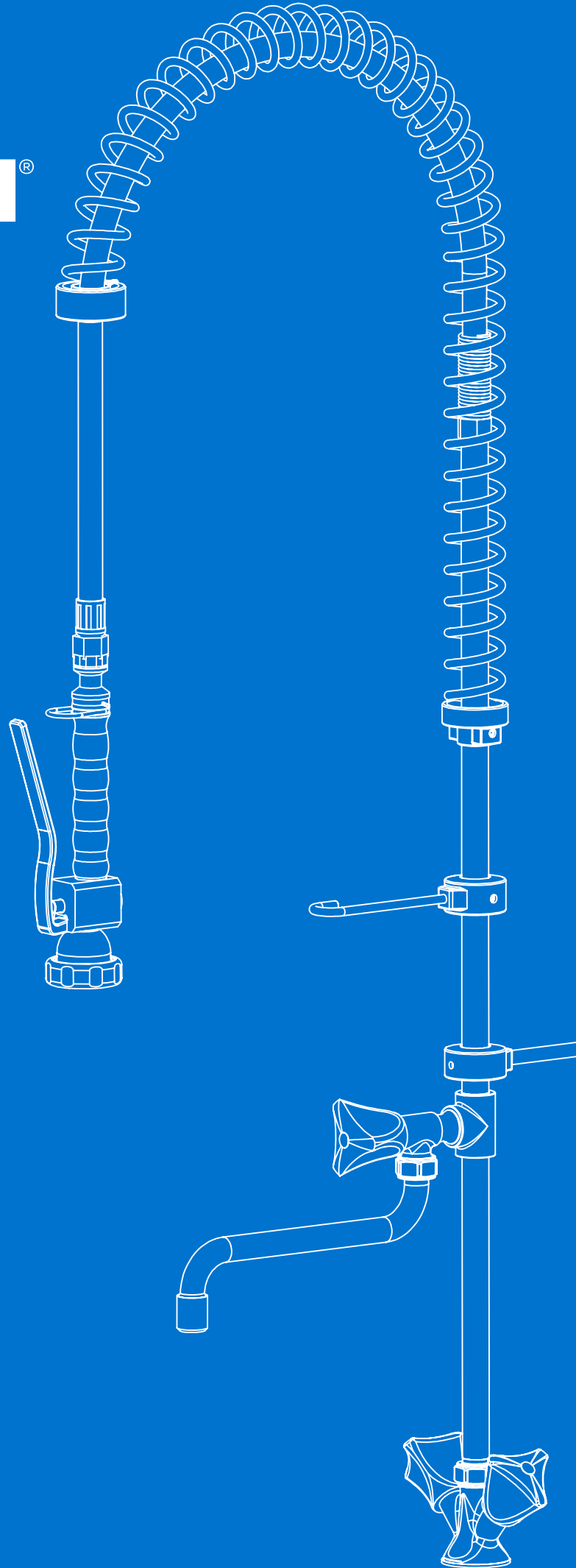



CANCAN was founded in 1958 by the late Salih Özüođurlu in its production center Ankara, in order to serve the food sector with repairing of orange squeezing machines, kitchen appliances and following with the production of these machinery.

As the second generation, Tunç ÖZÜÜĐURLU who took over the management in 1984 and continues to manage the company, saw that the foodservice industry would develop more and more in Turkey. In 1994, the company received the trademark registration.

The company located in Ankara, İvedik Organized Industrial Zone, started its production in Sakarya since the year 2000. Today the Company CANCAN, produces manual and automatic orange juicers, pomegranate-grapefruit-lemon juicer machines, washing equipments, can openers and peeler machines in its 3200 squaremeters production facility together with the help of Cnc machines and milling machines by shaping the metals, under one roof.



#### **Production Capacity and Exporting**

The annual production capacity of the company is around 50 thousand units. CANCAN, who attaches great importance to exporting, exports 35 percent of its production. Our primary goal is to become a sought-after brand worldwide with our quality.

#### **Annual Growth Rates**

Since 2016, our company has grown by 20% and 25% each year. The company exports directly to 5 continents and 30 countries and continues to search for new markets.

#### **Competitive Structure**

CANCAN, who prioritizes research and development and devotes a significant part of its annual turnover to R & D activities, competes with world brands with its innovative equipment.

#### **Sector-Specific**

Besides the production of industrial kitchen equipment and food preparation machines in accordance with the sector's developments and demands, CANCAN produces special machines that are not produced in Turkey before or that are in very few numbers produced.



*Discover The Power Of Water*

## **SPRAY PISTOL**

The spray pistol that provides pressurized water outlet can rotate 360 degrees around itself and thus provides comfortable use. It has a special design water outlet filter which prevents water consumption.

*Feel The Freedom Of Water*

# HOSE & PROTECTIVE SPIRAL SPRING

The hose, made of EPDM rubber, is flexible stainless steel braided and PVC coated. The spiral braided hose is resistant to 100 degree temperature.

The lacquered coated spring system prevents the hose from breaking and twisting. There are hose protective plastics at the end of the spring.

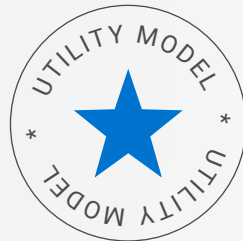

2014 - 06257



Designed For Working Area

# SINK MOUNTED MODELS

Sink Mounted Pre-rinse faucets are used in industrial kitchens, industrial dishwashing machines, vegetable and fruit washing units in the pre-washing stage.

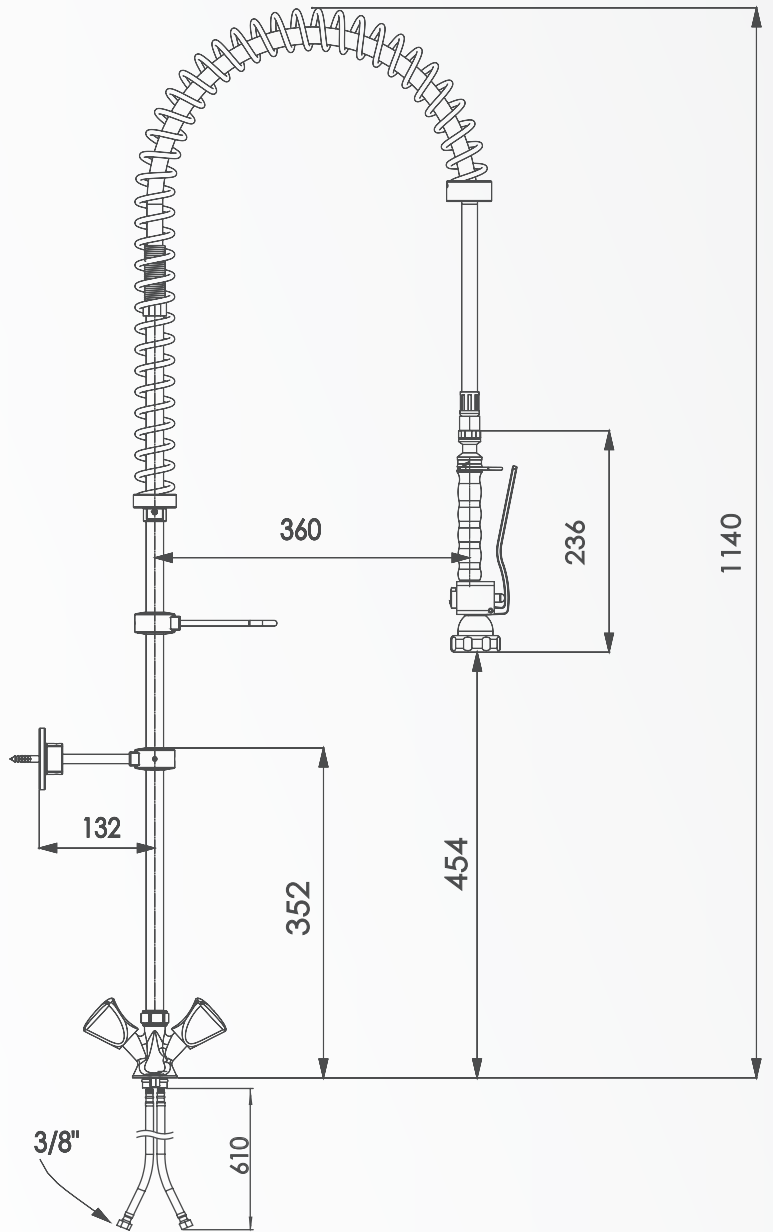

**Product Code:** 0501  
**Product Name:** MT01 Sink Mounted

---

<b>Weight:</b>	3 kg
<b>Width:</b>	15 cm
<b>Depth:</b>	44 cm
<b>Height:</b>	140 cm

---

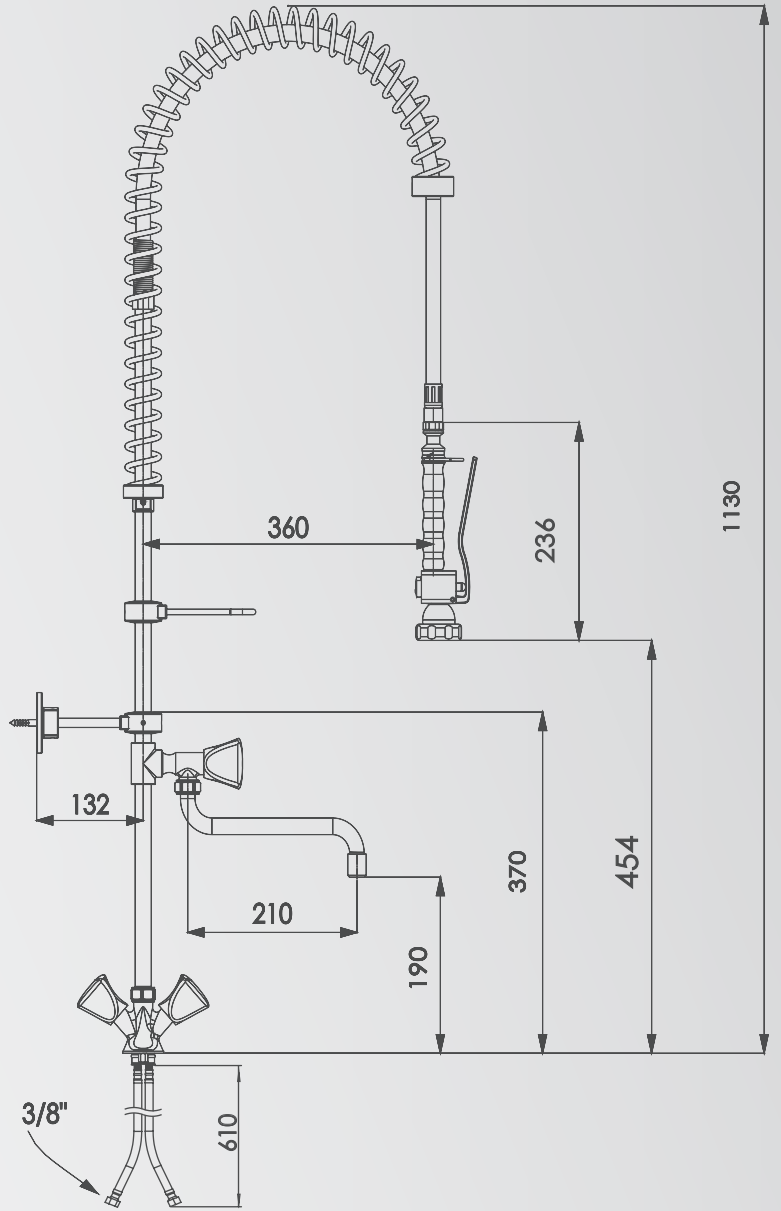

**Product Code:** 0502  
**Product Name:** MT02 Sink Mounted With Intermediate Tap

**Weight:** 4,8 kg  
**Width:** 15 cm  
**Depth:** 44 cm  
**Height:** 130 cm

*Designed For Best Place Saving*

# WALL MOUNTED MODELS

Wall Mounted Pre-rinse faucets are used in industrial kitchens, industrial dishwashing machines, vegetable and fruit washing units in the pre-washing stage.

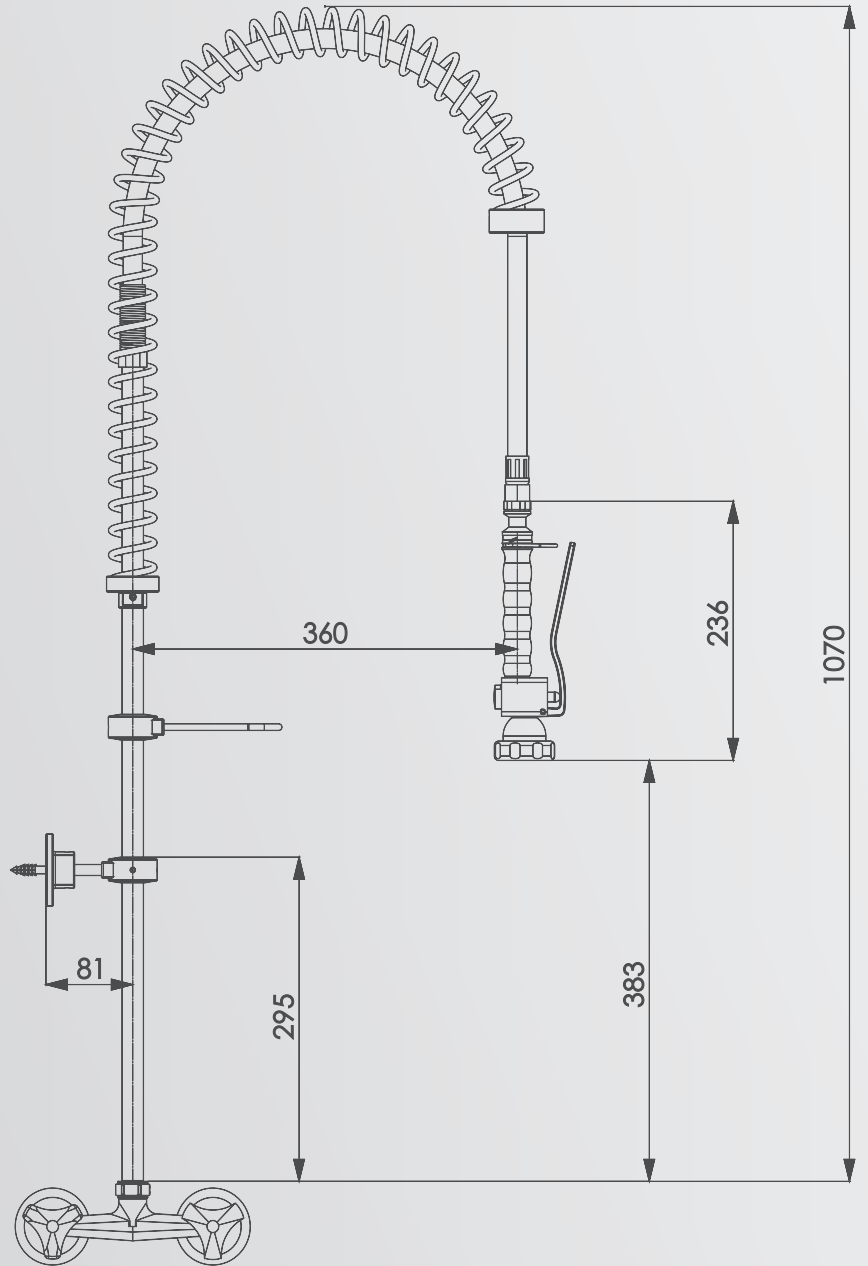

**Product Code:** 0503  
**Product Name:** MT03 Wall Mounted

---

<b>Weight:</b>	3 kg
<b>Width:</b>	15 cm
<b>Depth:</b>	44 cm
<b>Height:</b>	170 cm

---



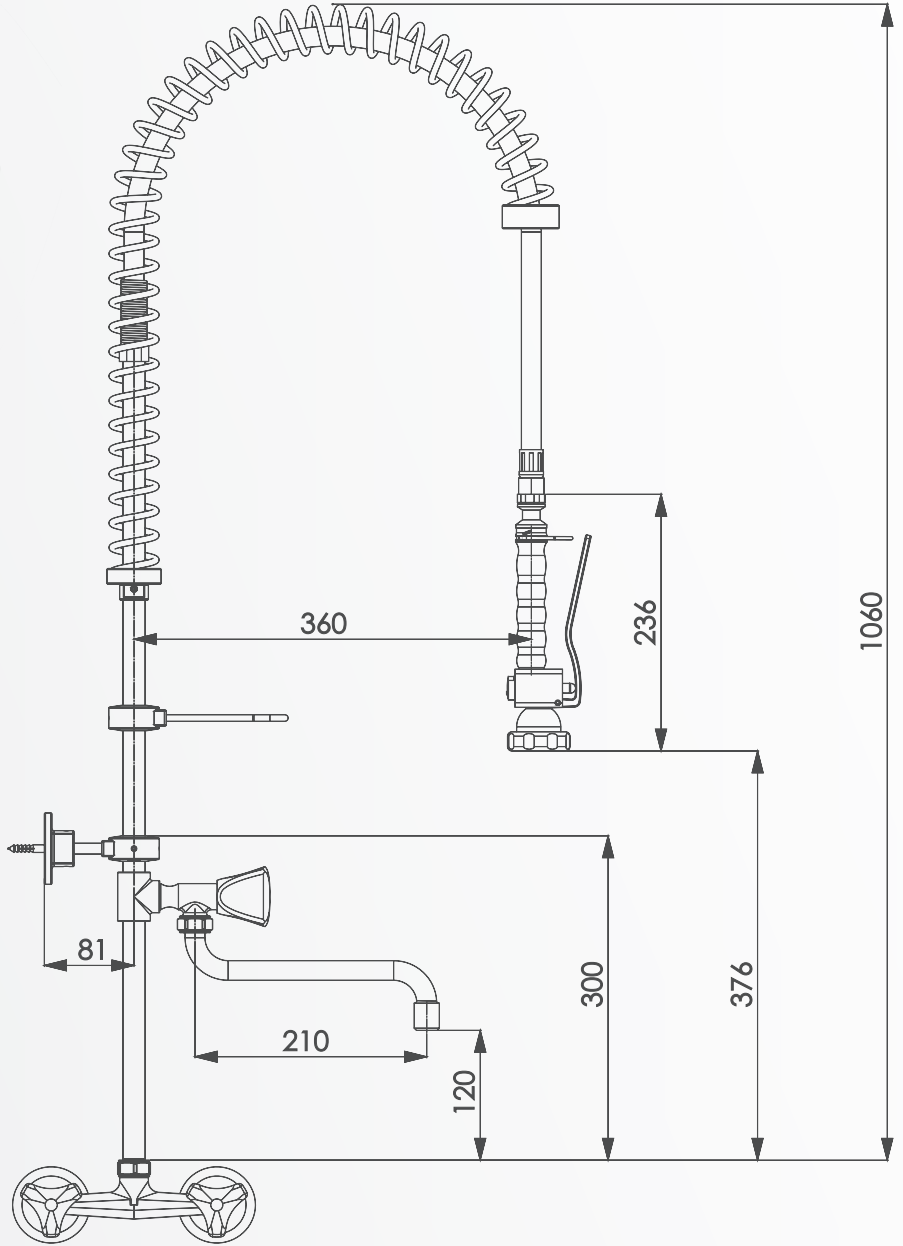

**Product Code:** 0504  
**Product Name:** MT04 Wall Mounted With Intermediate Tap

**Weight:** 4,8 kg  
**Width:** 15 cm  
**Depth:** 44 cm  
**Height:** 160 cm

*Designed For Perfect Minimalism*

# MINI SIZE MODELS

Mini Size Pre-rinse faucets are used in industrial kitchens, industrial dishwashing machines, vegetable and fruit washing units in the pre-washing stage.

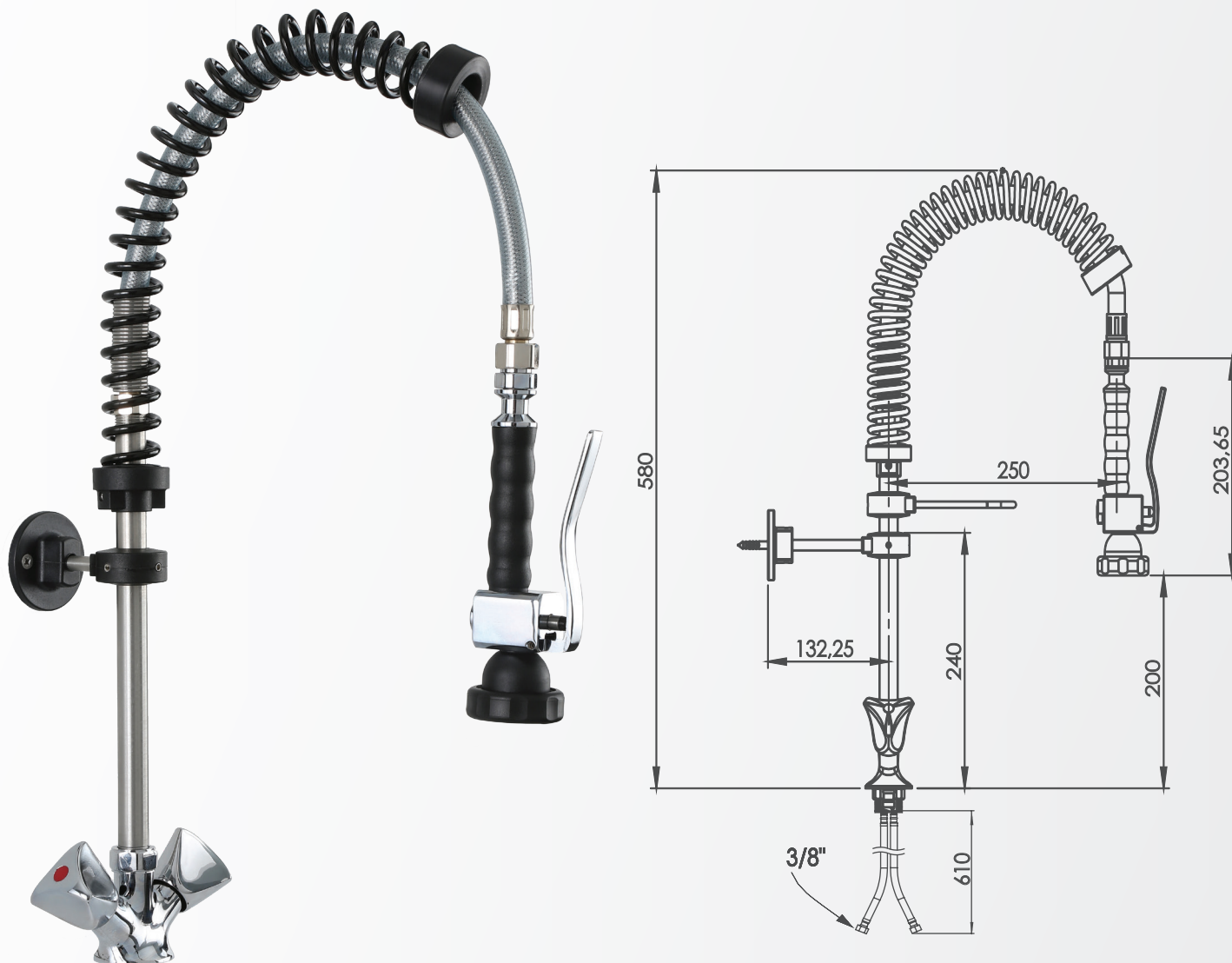

**Product Code:** 0505  
**Product Name:** MT05 Mini Size

---

<b>Weight:</b>	4,8 kg
<b>Width:</b>	15 cm
<b>Depth:</b>	44 cm
<b>Height:</b>	58 cm

---

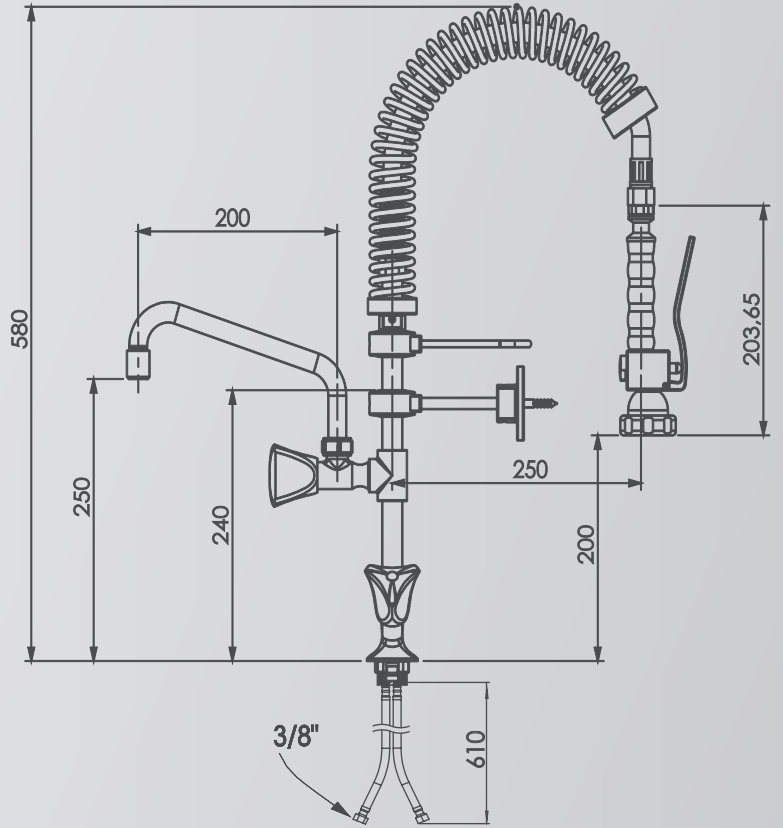

**Product Code:** 0506  
**Product Name:** MT06 Mini Size With Intermediate Tap

<b>Weight:</b>	4,8 kg
<b>Width:</b>	15 cm
<b>Depth:</b>	44 cm
<b>Height:</b>	58 cm



**NEW**

**DELUXE**

**SERIES**

New Deluxe Series

# SINK MOUNTED MODELS

Sink Mounted Pre-rinse faucets are used in industrial kitchens, industrial dishwashing machines, vegetable and fruit washing units in the pre-washing stage.

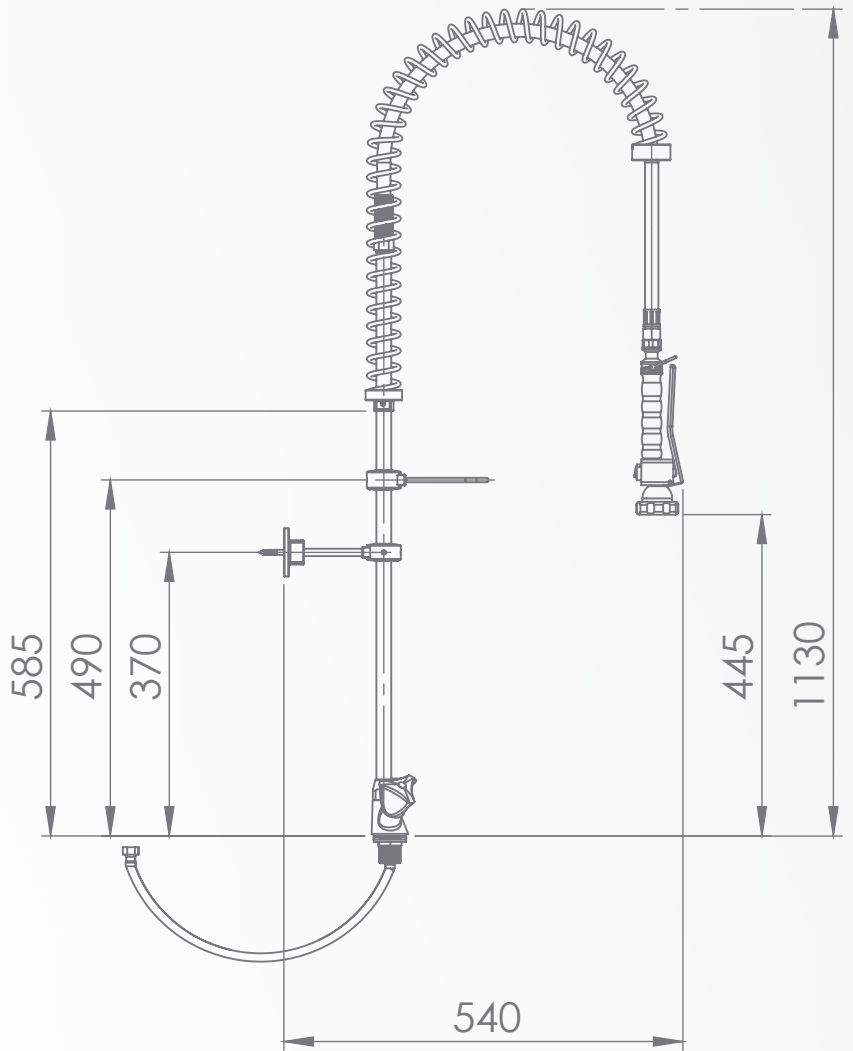

**Product Code:** 0507  
**Product Name:** Deluxe MT01 Sink Mounted

**Weight:** 4,6 kg  
.....  
**Width:** 16 cm  
.....  
**Depth:** 54 cm  
.....  
**Height:** 113 cm  
.....

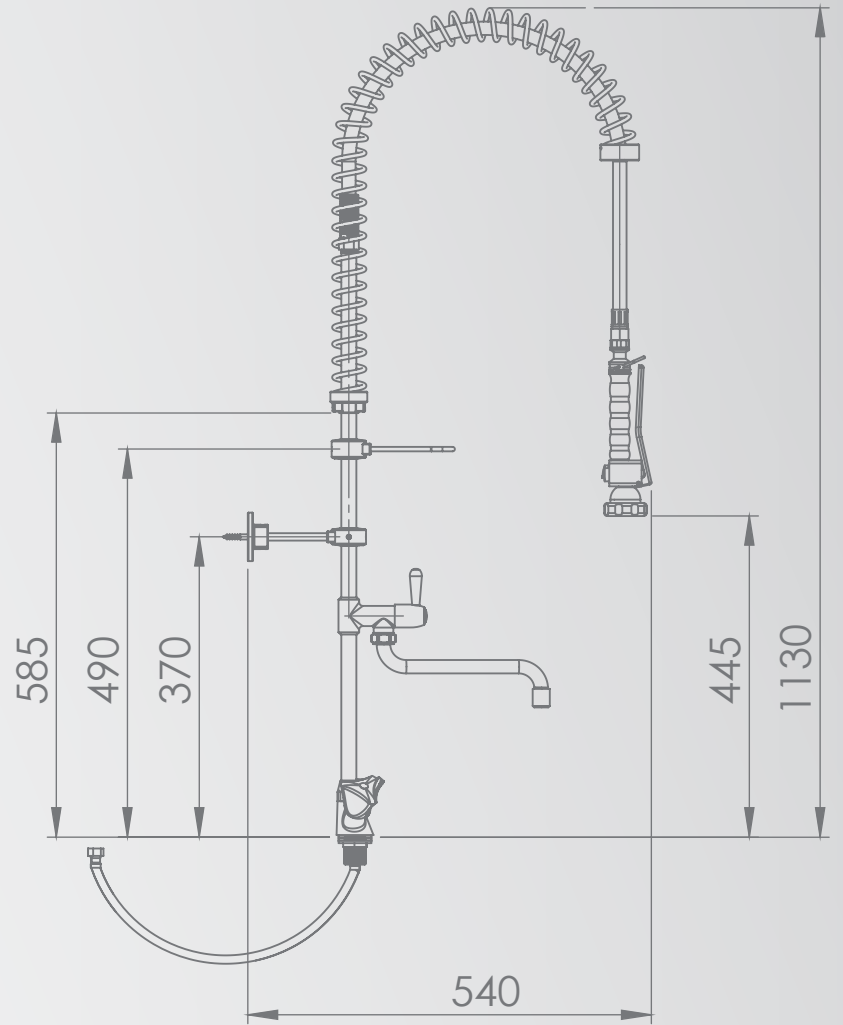

**Product Code:** 0508  
**Product Name:** Deluxe MT02 Sink Mounted With Intermediate Tap

**Weight:** 5,2 kg  
**Width:** 16 cm  
**Depth:** 54 cm  
**Height:** 114 cm

New Deluxe Series

# WALL MOUNTED MODELS

Wall Mounted Pre-rinse faucets are used in industrial kitchens, industrial dishwashing machines, vegetable and fruit washing units in the pre-washing stage.

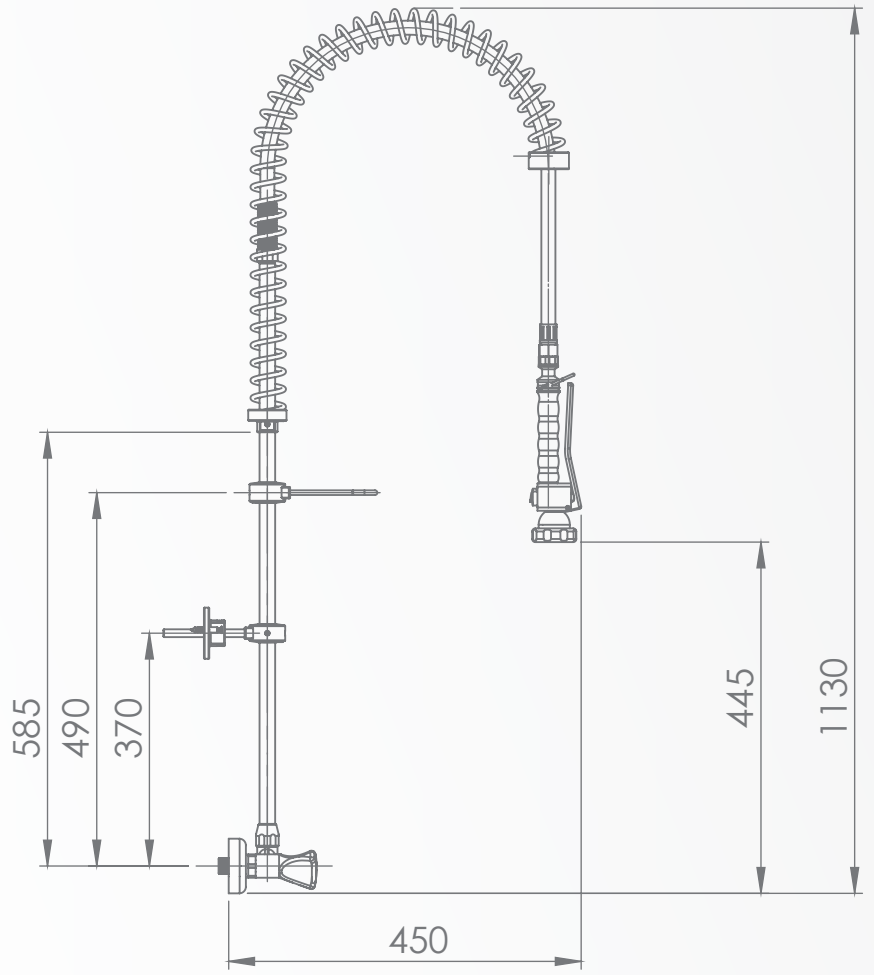

**Product Code:** 0512  
**Product Name:** Deluxe MT03 Wall Mounted

---

<b>Weight:</b>	4,5 kg
<b>Width:</b>	22 cm
<b>Depth:</b>	45 cm
<b>Height:</b>	113 cm

---



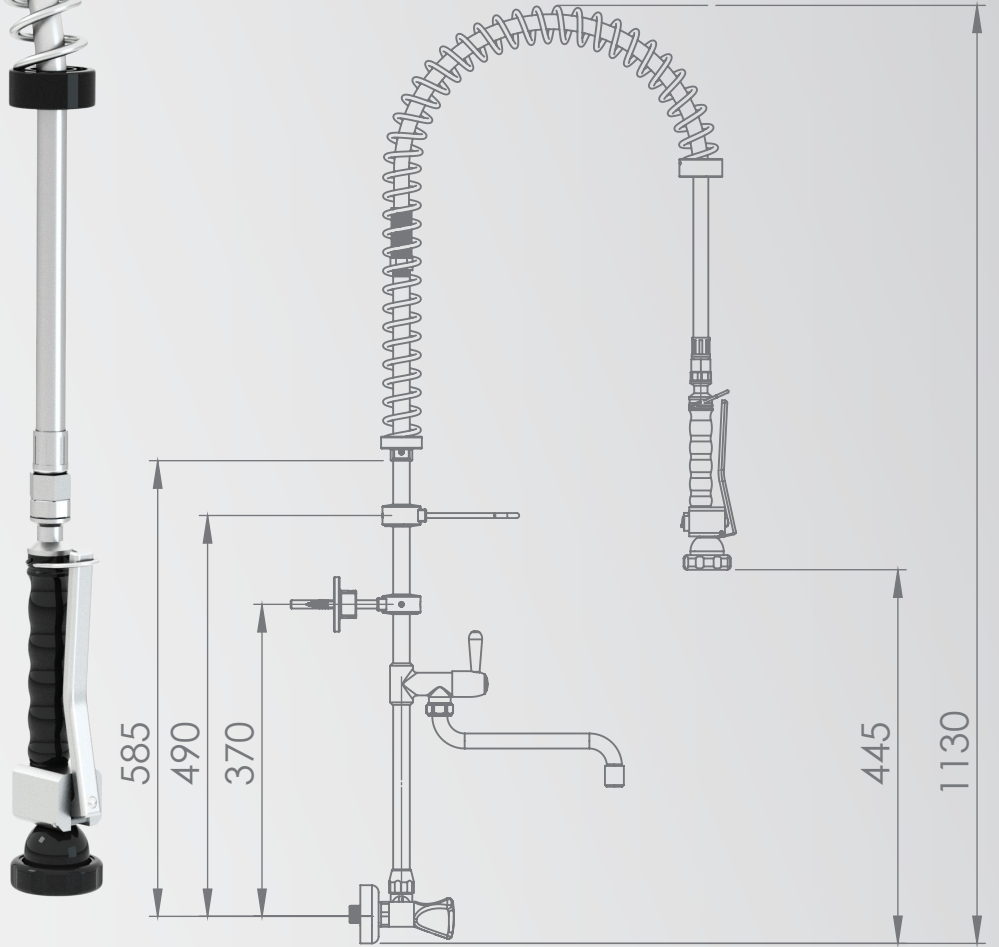

**Product Code:** 0513  
**Product Name:** Deluxe MT04 Sink Mounted With Intermediate Tap

**Weight:** 5,2 kg  
**Width:** 22 cm  
**Depth:** 45 cm  
**Height:** 113 cm

*New Deluxe Series*

# MINI SIZE MODELS

Mini Size Pre-rinse faucets are used in industrial kitchens, industrial dishwashing machines, vegetable and fruit washing units in the pre-washing stage.

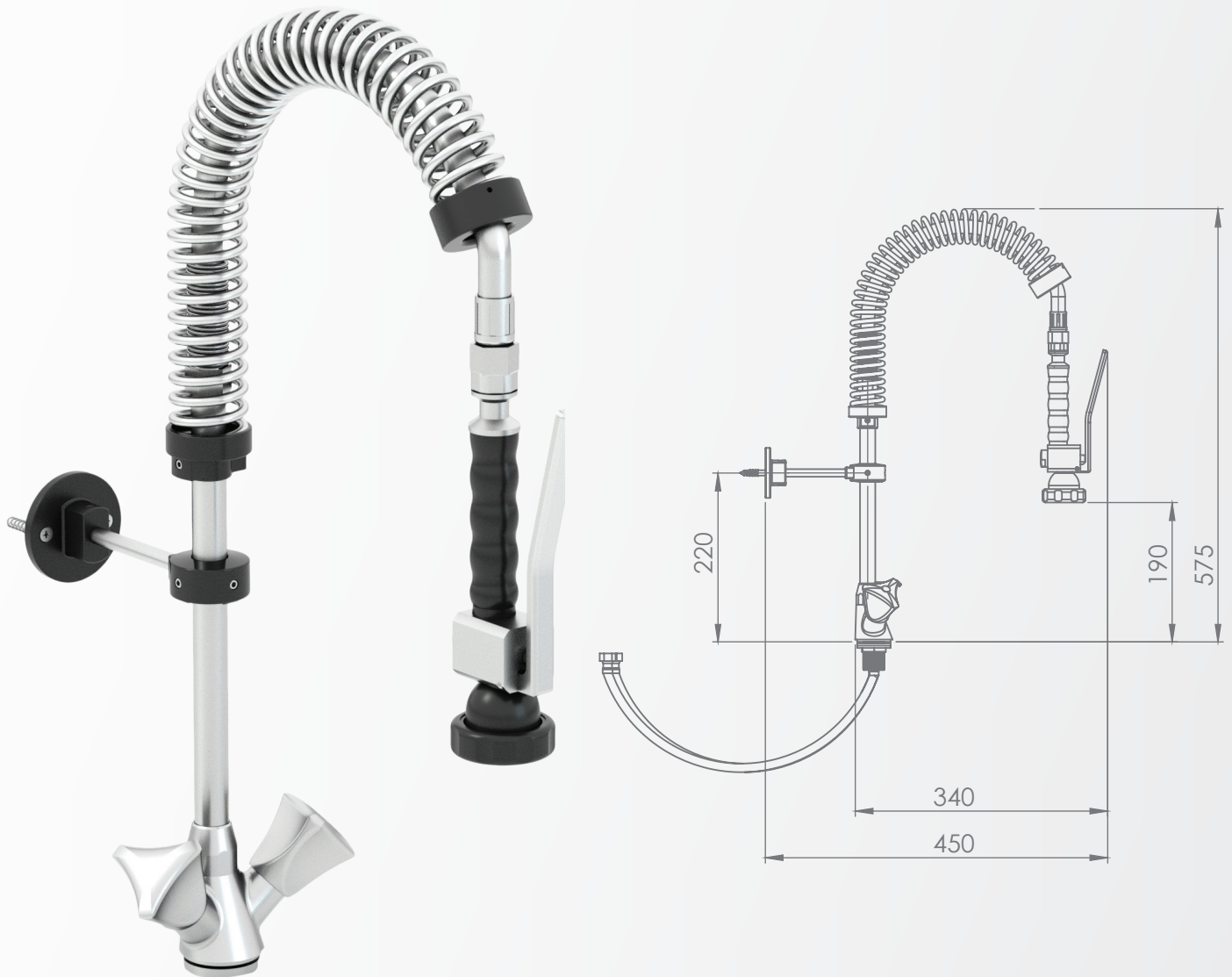

**Product Code:** 0509  
**Product Name:** Deluxe MT05 Mini Size

---

**Weight:** 3,9 kg  
.....  
**Width:** 16 cm  
.....  
**Depth:** 45 cm  
.....  
**Height:** 57,5 cm  
.....

---

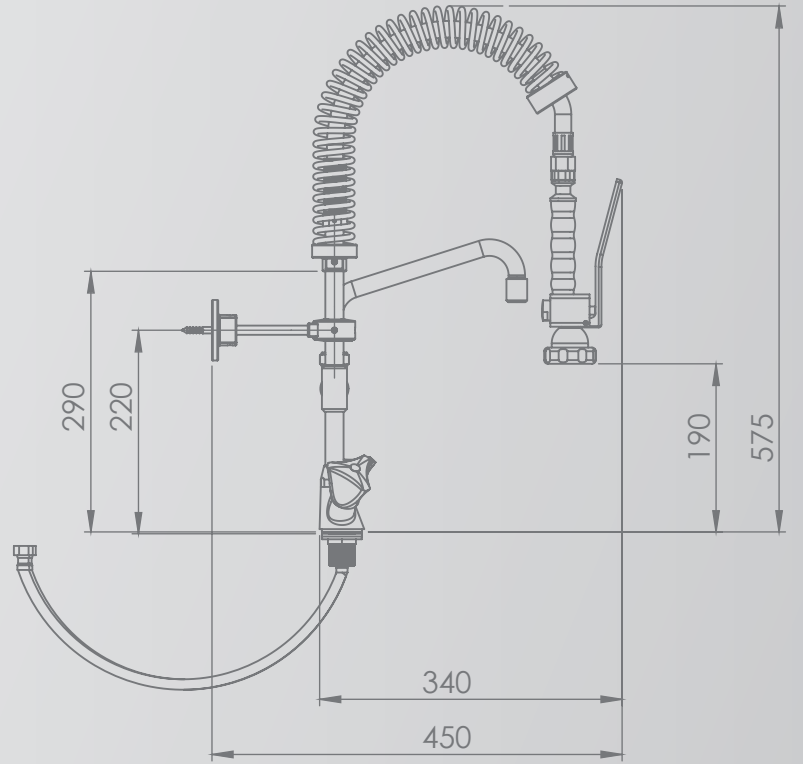

**Product Code:** 0510  
**Product Name:** Deluxe MT06 Mini Size With Intermediate Tap

**Weight:** 4,1 kg  
.....  
**Width:** 16 cm  
.....  
**Depth:** 45 cm  
.....  
**Height:** 57,5 cm  
.....



*Choice Of Professionals*

## **RETRACTABLE PRE-RINSE FAUCETS WITH REEL HOSE**

Retractable pre-rinse faucets with reel hoses are used in industrial kitchens, food preparation and mass food production facilities, industrial dishwashing machines, vegetable and fruit washing units, at the pre-washing stage in a minimum 100 squaremeters area with 2 stage collectable hose.

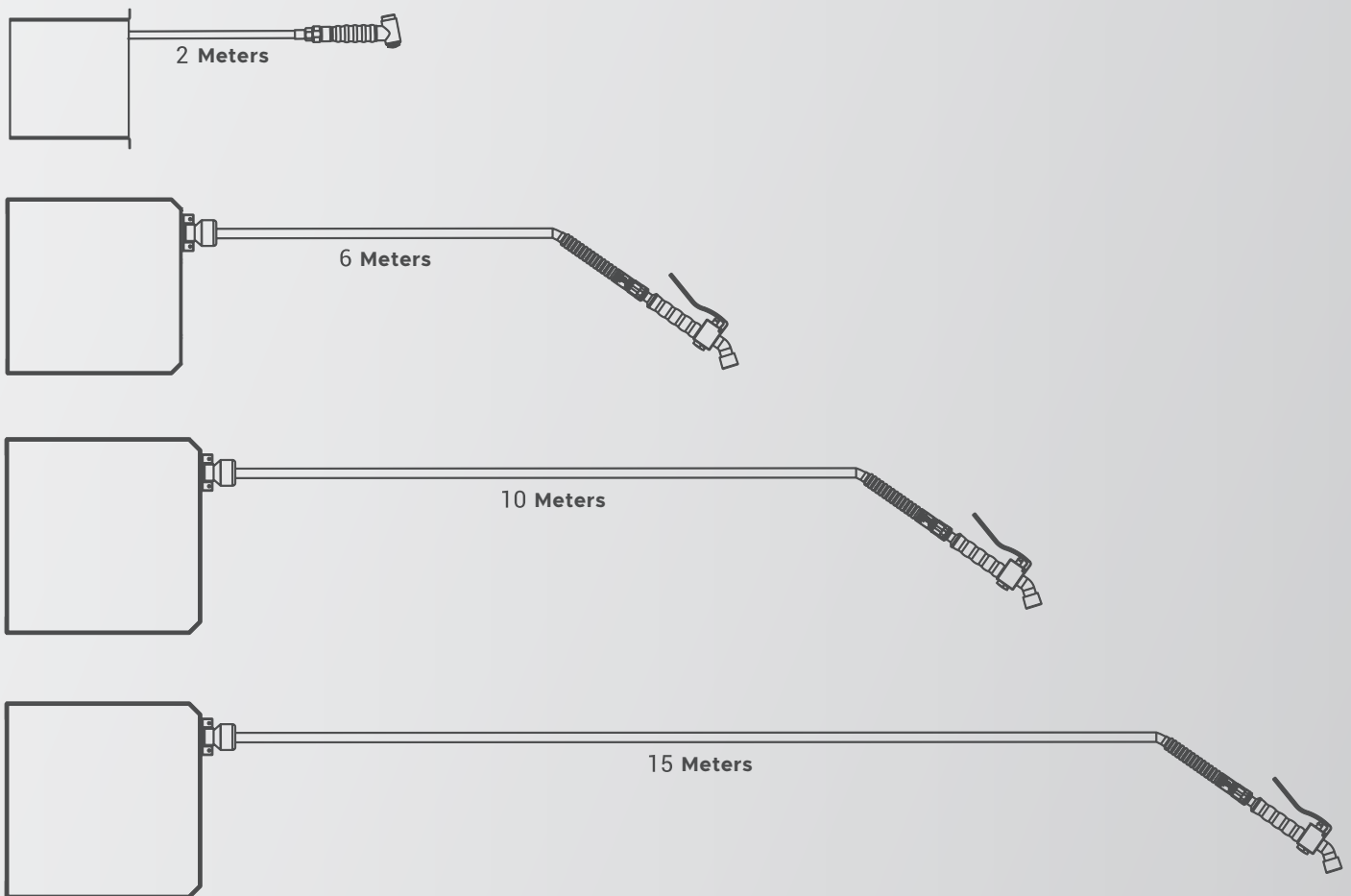

### *Cancan Retractable Pre - Rinse Faucets With Reel Hose*

## **8 REASONS TO CHOOSE**

1. Hose Spiral capacity of 16 mm thickness and 6m-10m-12m-15m length.
2. Oven type retractable pre-rinse faucet with reel hose designed to use for ovens with a 2 meters length hose.
3. 180 degree rotatable, wall mountable case.
4. Adjustable hose output feature.
5. Polyamide-bearing Pulley Hub.
6. 2-stage lockable feature.
7. Compliance with hygiene standards with 100% stainless body.
8. 30-50 bar working pressure resistant special production hose.

Possibility To Reach Everywhere

# RETRACTABLE MODELS



**Product Code:** 0906  
**Product Name:** 2 Meters Retractable



**Product Code:** 0901  
**Product Name:** 6 Meters Retractable

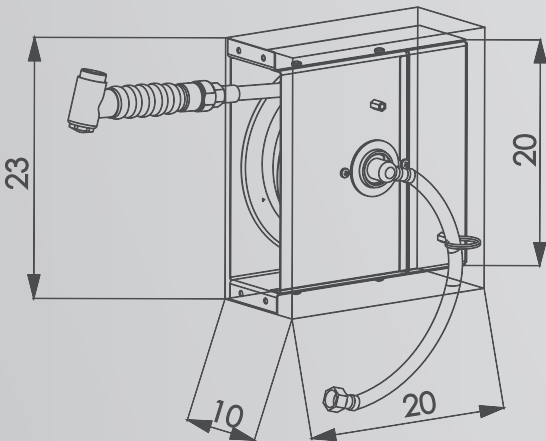

Weight:	3 kg
Width:	10 cm
Depth:	20 cm
Height:	23 cm

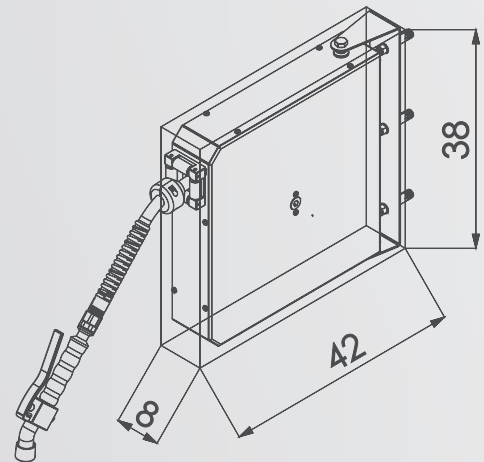

Weight:	9 kg
Width:	8 cm
Depth:	42 cm
Height:	38 cm



**Product Code:** 0902  
**Product Name:** 10 Meters Retractable

**Product Code:** 0904  
**Product Name:** 15 Meters Retractable

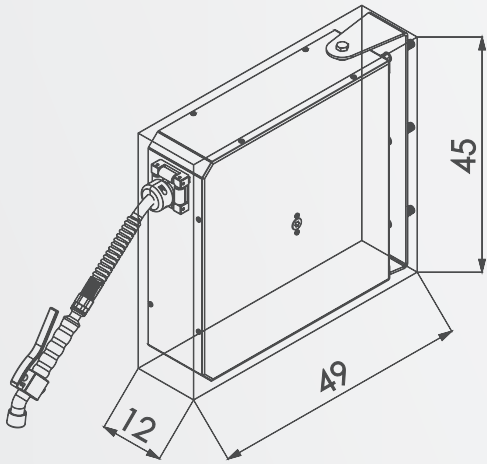

<b>Weight:</b>	13,5 kg
<b>Width:</b>	12 cm
<b>Depth:</b>	49 cm
<b>Height:</b>	45 cm

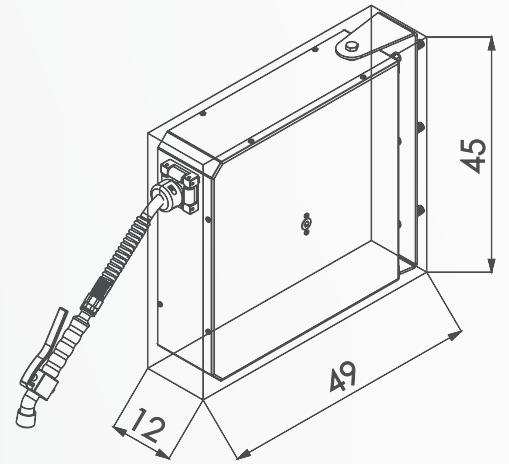

<b>Weight:</b>	17,5 kg
<b>Width:</b>	12 cm
<b>Depth:</b>	49 cm
<b>Height:</b>	45 cm

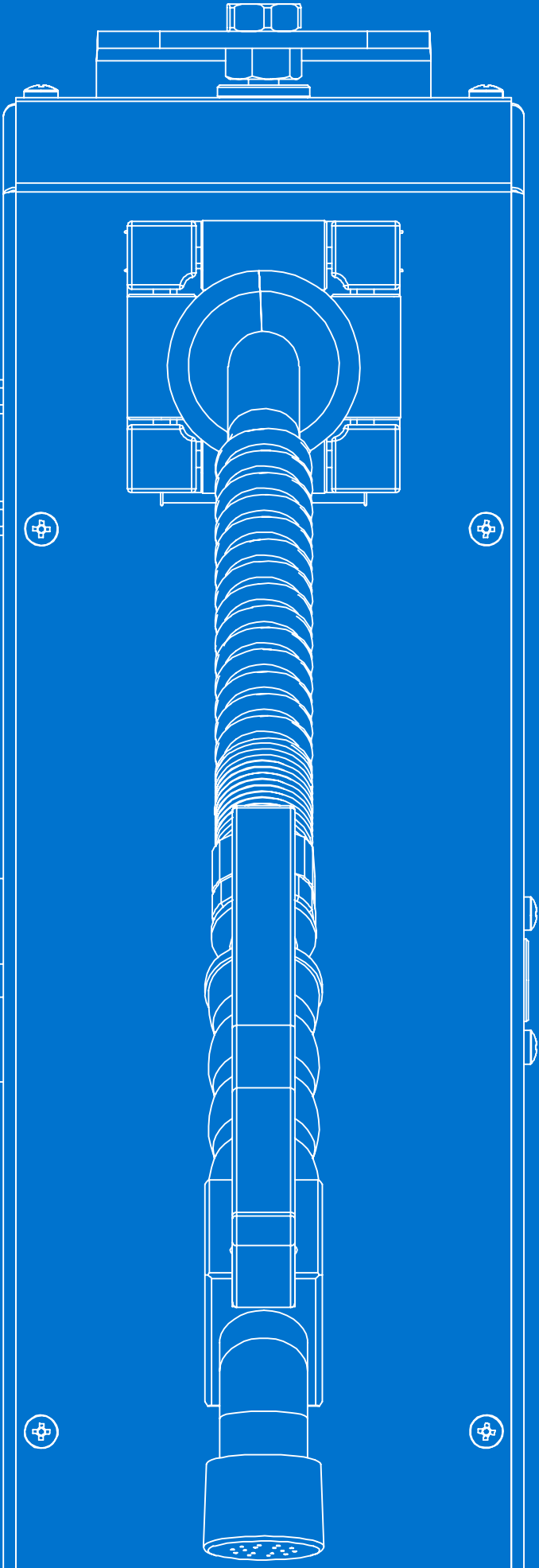

# CANCAN®

• SINCE 1958 •

## TURKEY HEAD OFFICE

**CANCAN MEYVE PRESLERİ SAN. VE. TİC. LTD. ŞTİ.**  
Modern San. Sit. Yeşiltepe Mah. No: 15/1  
Adapazarı / SAKARYA / TÜRKİYE

T: +90 (264) 291 49 44  
F: +90 (264) 291 49 45

## EUROPE CONTACT

Phone : +32 488 77 35 69  
E-Mail : info@cancanhoreca.com

## RUSSIA CONTACT

Phone : +7 916 861 10 97  
E-Mail : dymtro@cancan.com.tr

## BELARUS CONTACT

Phone : +375 29 533 83 99  
E-Mail : natalia@cancan.com.tr

## US OFFICE

**CANCAN INDUSTRIAL KITCHEN EQUIPMENTS INC**  
Turkish Trade Center Chicago 2800-2900  
Lively Blvd. Elk Grove IL60007 USA

T: +1 847 756 72 68  
F: +1 847 430 48 03